

Service Manual

Cassette Deck

RS-M88

 (Black Face)
 (Silver Face)

Quartz-Locked Direct-Drive Cassette Deck
 with Metal Tape Recording Capability

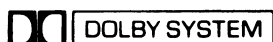

This is the Service Manual for the following areas.

- ☐ ... For All European areas except United Kingdom.
- ☒ ... For United Kingdom.



Professional Series

RS-M85 MECHANISM SERIES

Specifications

Track system:	4-track 2-channel stereo recording and playback	Outputs:	LINE; output level 700 mV, load impedance 22 k Ω over
Tape speed:	4.8 cm/s		HEADPHONE; output level 140 mV, load impedance 8 Ω
Wow and flutter:	0.035% (WRMS), $\pm 0.10\%$ (DIN)	Rec/PB connection:	5 P DIN type; input sensitivity 0.25 mV, impedance 4 k Ω
Frequency response: Metal tape;	20 — 20,000 Hz		output level 700 mV, impedance 1.5 k Ω
	30 — 18,000 Hz (DIN)	Bias frequency:	85 kHz
	30 — 17,000 Hz ± 3 dB	Motors:	2-motor system
(0 VU)	40 — 13,000 Hz ± 3 dB		Capstan; 1-quartz control phase-locked DC brushless direct-drive motor
CrO ₂ /Fe-Cr tape;	20 — 18,000 Hz		Reel table; 1-DC coreless motor
	30 — 18,000 Hz (DIN)	Heads:	2-head system
	30 — 16,000 Hz ± 3 dB		1-SX (Sendust Extra) head for rec/playback
Normal tape;	20 — 16,000 Hz		1-sendust/ferrite double-gap head for erasure
	30 — 16,000 Hz (DIN)	Power requirements:	AC; 110/125/220/240 V, 50-60 Hz
	30 — 14,000 Hz ± 3 dB		Preset power voltage; 240V only for England.
Signal-to-noise ratio: Dolby [*] NR in;	69 dB (above 5 kHz)	Power consumption:	35 W
	Dolby NR out; 59 dB (signal level = max. recording level, Fe-Cr/CrO ₂ type tape)	Dimensions:	9.7 cm(H) \times 45.0 cm(W) \times 40.3 cm(D)
Fast forward and		Weight:	10.5 kg
rewind time: Approx. 80 seconds with C-60 cassette tape			
Inputs:	MIC; sensitivity 0.25 mV, applicable microphone impedance 400 Ω — 10 k Ω		
	LINE; sensitivity 60 mV, input impedance 68 k Ω		

Specifications are subject to change without notice.

* 'Dolby' and the double-D symbol are trademarks of Dolby Laboratories.

Technics

Matsushita Electric Trading Co., Ltd.

P.O. Box 288, Central Osaka Japan

LOCATION OF CONTROLS AND COMPONENTS

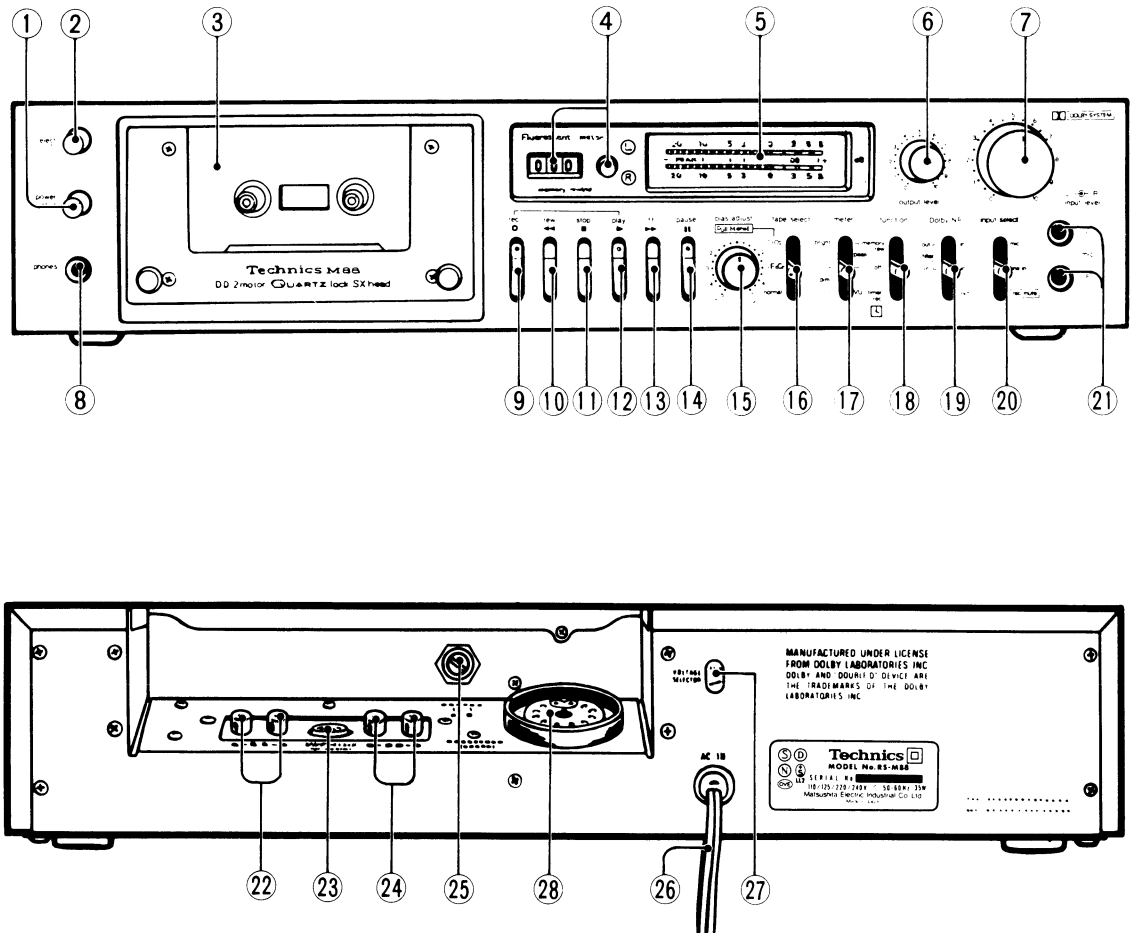

Fig. 1

- | | |
|--|--|
| <ul style="list-style-type: none"> ① Power Switch (power) ② Eject Button (eject) ③ Cassette Holder ④ Tape Counter, Reset Button ⑤ FL (Fluorescent Level) Meters ⑥ Output Level Control (output level) ⑦ Input Level Controls (input level) ⑧ Headphones Jack (phones) ⑨ Record Button with Record Indication Lamp (record) (○) ⑩ Rewind Button (rewind) (◀◀) ⑪ Stop Button (stop) (■) ⑫ Playback Button with Playback Indication Lamp (play) (▶▶) ⑬ Fast-Forward Button (ff) (▶▶▶) ⑭ Pause Button with Pause Indication Lamp (pause) () ⑮ Bias-Adjustment Control/"Metal tape" selector (bias adjust)(pull Metal) | <ul style="list-style-type: none"> ⑯ Tape Selector (tape select) ⑰ Meter-Brightness/Function Selector (meter) ⑱ Function Selector (function) ⑲ Dolby Noise-Reduction Switch (Dolby NR) ⑳ Input Selector (input select) ㉑ Microphone Jacks (mic) ㉒ Line Output Jacks (LINE OUT) (R, L) ㉓ Record/Playback Connection Socket (REC/PB) ㉔ Line Input Jacks (LINE IN) (R, L) ㉕ Meter-Brightness-Adjustment Control (meter light) ㉖ Power Cord ㉗ Voltage Selector (VOLTAGE SELECTOR) ㉘ Remote-Control Connector (REMOTE CONTROL) |
|--|--|

DISASSEMBLY INSTRUCTIONS

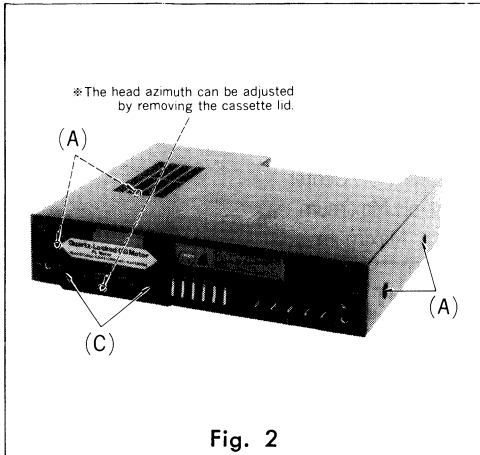

Fig. 2

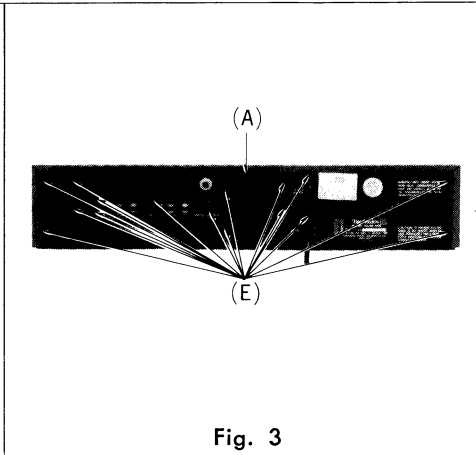

Fig. 3

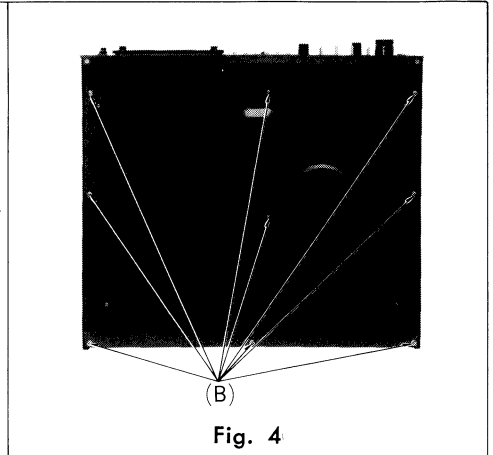

Fig. 4

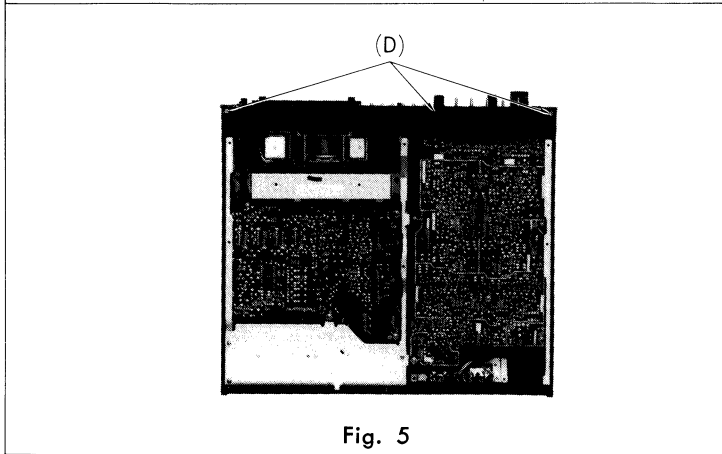

Fig. 5

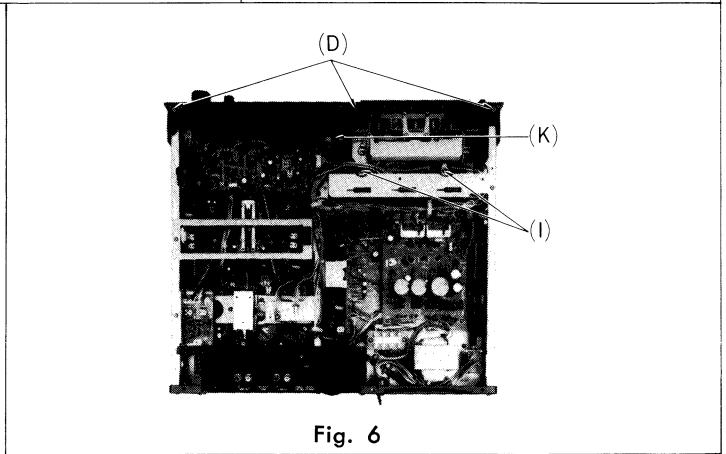

Fig. 6

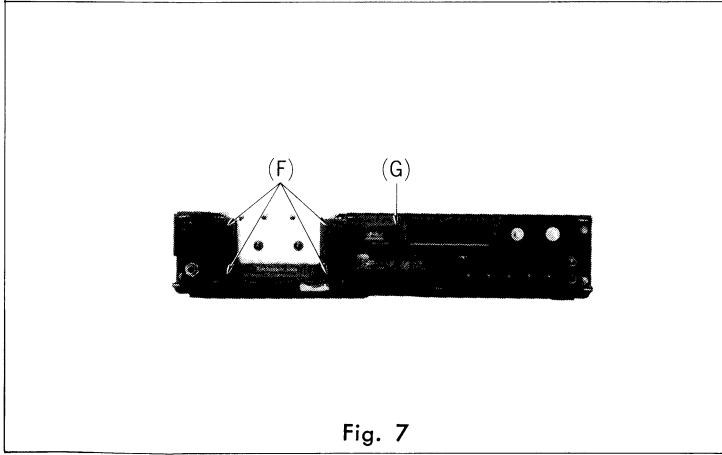

Fig. 7

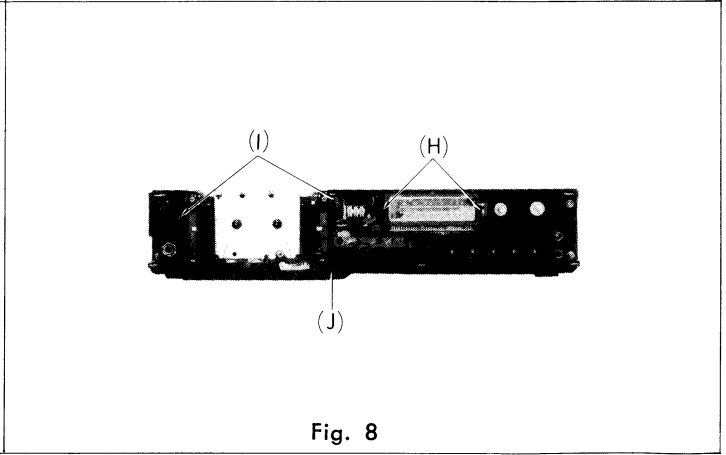

Fig. 8

Procedure	To remove	Remove	Shown in fig.
1	Case cover	• 5 black screws(A)	2, 3
2	Bottom cover	• 9 screws(B)	4
3	Front panel	• 2 cassette lid holding screws(C) • 6 red screws(D)	2, 5, 6
4	Back cover	• 16 black screws(E)	3
5	Cassette holder	• 4 screws(F)	7
5	FL level meter	• Meter cover(G) • 2 meter holders.....(H)	7, 8
5	Mechanism	• 4 red screws(I) • 1 black screw(J) • Tape counter belt.....(K)	6, 8, 8, 6

DISASSEMBLY INSTRUCTIONS

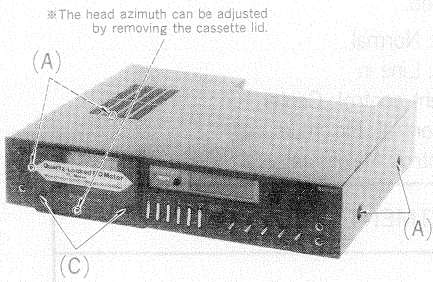

Fig. 2

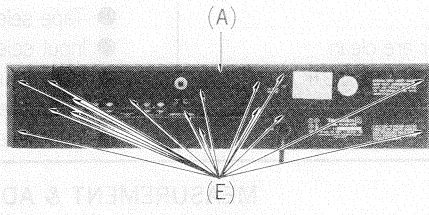

Fig. 3

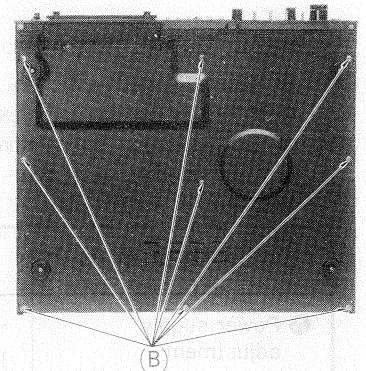

Fig. 4

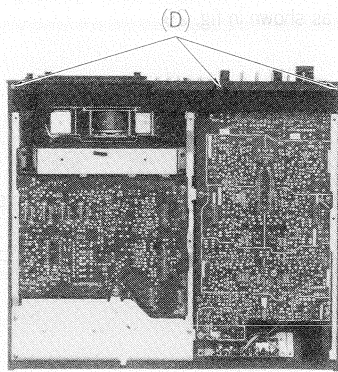

Fig. 5

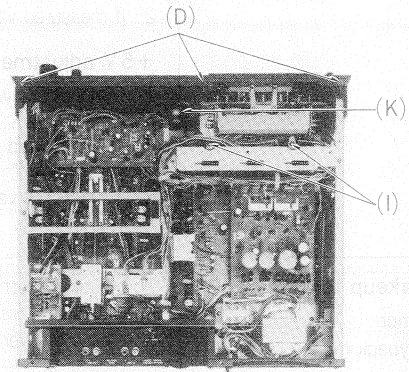

Fig. 6

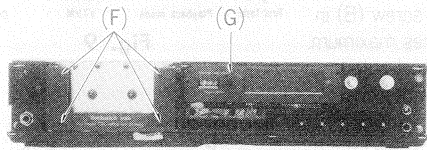

Fig. 7

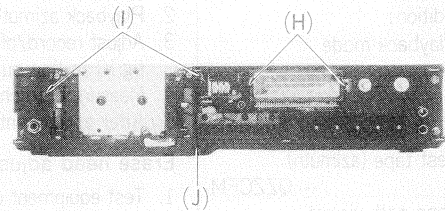

Fig. 8

Procedure	To remove	Remove	Shown in fig.
1	Case cover	• 5 black screws(A)	2, 3
2	Bottom cover	• 9 screws(B)	4
3	Front panel	• 2 cassette lid holding screws(C) • 6 red screws(D)	2 5, 6
4	Back cover	• 16 black screws(E)	3
5	Cassette holder	• 4 screws(F)	7
5	FL level meter	• Meter cover(G) • 2 meter holders(H)	7 8
5	Mechanism	• 4 red screws(I) • 1 black screw(J) • Tape counter belt(K)	6, 8 8 6

MEASUREMENT AND ADJUSTMENT METHODS

NOTE: Set lever switches and controls in the following positions, unless otherwise specified.

- Make sure heads are clean.
- Tape selector: Normal
- Make sure capstan and pressure roller are clean.
- Input selector: Line in
- Judgeable room temperature: $20 \pm 5^\circ\text{C}$ ($68 \pm 9^\circ\text{F}$)
- Bias adjustment control: Center
- Meter selector: Peak, dim
- Output level control: Maximum
- Dolby NR switch: OUT
- Input level control: Maximum

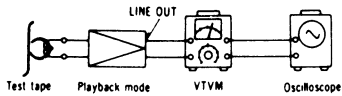
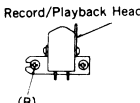
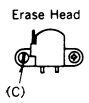
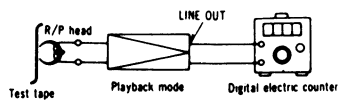
ITEM	MEASUREMENT & ADJUSTMENT
<p>A Power supply adjustment</p>	<p>+20V adjustment</p> <ol style="list-style-type: none"> Connect voltmeter to the test point V on the power circuit board and read voltage. <div style="border: 1px solid black; padding: 5px; width: fit-content; margin: 5px auto;"> <p>Standard value: $+20 \pm 0.5\text{V}$</p> </div> <ol style="list-style-type: none"> If measured value is not in standard, adjust VR401 as shown in fig. 29. <p>+5V adjustment</p> <ol style="list-style-type: none"> Connect DC voltmeter to the test point V2 on the power circuit board and read voltage. <div style="border: 1px solid black; padding: 5px; width: fit-content; margin: 5px auto;"> <p>Standard value: $+5 \pm 0.4\text{V}$</p> </div> <ol style="list-style-type: none"> If measured value is not in standard, connect the point A on the power circuit board as shown on page 14.
<p>B Takeup tension</p> <p>Condition: * Playback mode</p> <p>Equipment: * Cassette torque meter (QZZSRKCT)</p>	<ol style="list-style-type: none"> Mount cassette torque meter on UNIT. Place UNIT into playback mode and read takeup torque. Measure several times and determine the mean value. <div style="border: 1px solid black; padding: 5px; width: fit-content; margin: 5px auto;"> <p>Standard value: $34 \pm 6\text{ gr-cm}$</p> </div> <ol style="list-style-type: none"> If measured value is not in standard, adjust VR601.
<p>C Head azimuth adjustment</p> <p>Condition: * Playback mode</p> <p>Equipment: * VTVM * Oscilloscope * Test tape (azimuth) ... QZZCFM * Tape path viewer ... QZZCRD</p>	<p>Record/playback head adjustment</p> <ol style="list-style-type: none"> Test equipment connection is shown in fig. 9. Playback azimuth tape (QZZCFM 8kHz). Adjust record/playback head angle adjustment screw (B) in fig.10 so that output level at LINE OUT becomes maximum. Measure both channels, and adjust levels for equal output. After adjustment lock head adjustment screw with lacquer.  <p style="text-align: center;">Fig. 9</p> <p>Erase head adjustment</p> <ol style="list-style-type: none"> Test equipment connection is the same above but use the tape path viewer (QZZCRD) instead of test tape (QZZCFM). Playback this tape. Adjust screw (C) shown in fig. 11 so that the tape may not get curled or malformed by tape guide of the erase head. After adjustment, lock head adjust screw with lacquer.  <p style="text-align: center;">Fig. 10</p>  <p style="text-align: center;">Fig. 11</p>
<p>D Tape speed</p> <p>Condition: * Playback mode</p> <p>Equipment: * Digital electronic counter * Test tape ... QZZCWAT</p>	<p>Tape speed accuracy</p> <ol style="list-style-type: none"> Test equipment connection is shown in fig. 12. Playback test tape (QZZCWAT 3,000Hz), and supply playback signal to frequency counter. Measure this frequency. On the basis of 3,000Hz, determine value by following formula: $\text{Tape speed accuracy} = \frac{f - 3,000}{3,000} \times 100 (\%)$ <p style="text-align: center;">where, f = measured value</p> <ol style="list-style-type: none"> Take measurement at middle section of tape. <div style="border: 1px solid black; padding: 5px; width: fit-content; margin: 5px auto;"> <p>Standard value: $\pm 0.4\%$</p> </div>  <p style="text-align: center;">Fig. 12</p>

ITEM	MEASUREMENT & ADJUSTMENT
	<p>Tape speed fluctuation</p> <p>Make measurements in same manner as above (beginning, middle and end of tape), and determine the difference between maximum and minimum values and calculate as follows:</p> $\text{Tape speed fluctuation} = \frac{f_1 - f_2}{3,000} \times 100 (\%)$ <p>f_1 = maximum value, f_2 = minimum value</p> <div style="border: 1px solid black; padding: 5px; width: fit-content; margin: 10px auto;"> <p>Standard value: Less than 0.3%</p> </div>
<p>Ⓔ Capstan motor circuit adjustment</p> <p>Condition:</p> <ul style="list-style-type: none"> * Playback mode <p>Equipment:</p> <ul style="list-style-type: none"> * VTVM * Oscilloscope 	<p>A. Standard DC power supply voltage adjustment</p> <ol style="list-style-type: none"> 1. Measure the DC voltage between central point of VR703 and ⑥ terminal of IC702 as shown in fig.13. <div style="border: 1px solid black; padding: 5px; width: fit-content; margin: 10px auto;"> <p>Standard voltage: $0 \pm 0.05V$</p> </div> <ol style="list-style-type: none"> 2. If measured voltage is not within standard, adjust VR703. <p>B. Phase lock point adjustment</p> <ol style="list-style-type: none"> 1. Measure the DC voltage between ④ terminal of IC702 and ground as shown in fig. 14. <div style="border: 1px solid black; padding: 5px; width: fit-content; margin: 10px auto;"> <p>Standard voltage: $5.2 \pm 0.1V$</p> </div> <ol style="list-style-type: none"> 2. If measured voltage is not within standard, adjust VR702. <p>C. Position detecting signal output level adjustment</p> <ol style="list-style-type: none"> 1. Connect oscilloscope to test point (T.P. P-V). 2. Measure the peak-to-peak voltage of position detection signal of test point with the oscilloscope. 3. If the measured signal voltage is markedly different from the voltage shown in fig. 16, make the necessary adjustment with the VR701.
<p>Ⓕ Playback frequency response</p> <p>Condition:</p> <ul style="list-style-type: none"> * Playback mode * Output level control ... MAX <p>Equipment:</p> <ul style="list-style-type: none"> * VTVM * Oscilloscope * Test tape ... QZZCFM 	<ol style="list-style-type: none"> 1. Test equipment connection is as same as "Head azimuth adjustment" but use the test tape (QZZCFM) instead of head azimuth tape (See fig. 9). 2. Place UNIT into playback mode. 3. Playback the frequency response test tape (QZZCFM). 4. Measure output level at 12.5kHz, 8kHz, 4kHz, 1kHz, 250Hz, 125Hz and 63Hz, and compare each output level with the standard frequency 315Hz, at LINE OUT. 5. Make measurement for both channels. 6. Make sure that the measured value is within the range specified in the frequency response chart. 7. If measured value is not in standard, adjust VR1 (L-CH), VR2 (R-CH) (See fig. 29). <div style="text-align: center;"> <p>Playback frequency response chart</p> <p>Fig. 17</p> </div>
<p>Ⓖ Playback gain</p> <p>Condition:</p> <ul style="list-style-type: none"> * Playback mode * Output level control ... MAX <p>Equipment:</p> <ul style="list-style-type: none"> * VTVM * Oscilloscope * Test tape ... QZZCFM 	<ol style="list-style-type: none"> 1. Test equipment connection is shown in fig. 9. 2. Playback standard recording level portion on test tape (QZZCFM 315Hz), and using VTVM measure the output level at LINE OUT jack. 3. Make measurement for both channels. <div style="border: 1px solid black; padding: 5px; width: fit-content; margin: 10px auto;"> <p>Standard value: $0.66 \pm 0.05V$</p> </div> <p>Adjustment</p> <ol style="list-style-type: none"> 1. If measured value is not standard, adjust VR3 (L-CH), VR4 (R-CH) (See fig. 29). 2. After adjustment, check "Playback frequency response" again.

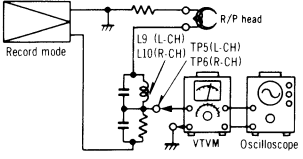
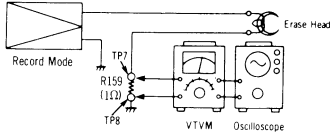
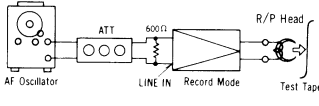
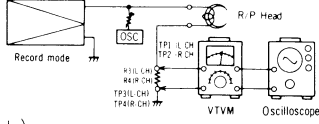
ITEM	MEASUREMENT & ADJUSTMENT
<p>H Bias leak</p> <p>Condition:</p> <ul style="list-style-type: none"> * Record mode * Input level control ... MAX <p>Equipment:</p> <ul style="list-style-type: none"> * VTVM * Oscilloscope 	<ol style="list-style-type: none"> 1. Test equipment connection is shown in fig. 18 (See AMP circuit board on page 10). 2. Place UNIT into record mode. 3. Adjust trap coils L9 (L-CH), L10 (R-CH), so that measured value becomes minimum (See fig. 29). 4. Make adjustment for both channels.  <p style="text-align: right;">Fig. 18</p>
<p>I Erase current</p> <p>Condition:</p> <ul style="list-style-type: none"> * Record mode * Bias adjustment control ... Center <p>Equipment:</p> <ul style="list-style-type: none"> * VTVM * Oscilloscope 	<ol style="list-style-type: none"> 1. Test equipment connection is shown in fig. 19. 2. Place UNIT into record mode and measure voltage at test point 7. 3. Determine erase current with the following formula. $\text{Erase current (A)} = \frac{\text{Voltage across both ends of R159}}{1 (\Omega)}$ <div style="border: 1px solid black; padding: 5px; margin: 10px auto; width: fit-content;"> <p style="text-align: center;">Standard value: 95 ± 5 mA (Tape selector ... Metal)</p> </div> <ol style="list-style-type: none"> 4. If measured value is not within standard, adjust VR803.  <p style="text-align: right;">Fig. 19</p>
<p>J Bias current</p> <p>Condition:</p> <ul style="list-style-type: none"> * Record mode * Bias adjustment control ... Center <p>Equipment:</p> <ul style="list-style-type: none"> * VTVM * Oscilloscope * AF oscillator * ATT * Test tape (reference blank tape) <ul style="list-style-type: none"> ... QZZCRA for Normal ... QZZCRX for CrO₂ ... QZZCRY for Fe-Cr ... QZZCRZ for Metal 	<p>A. Adjustment of metal tape</p> <ol style="list-style-type: none"> 1. Test equipment connection is shown in fig. 20. 2. Place the test tape (QZZCRZ) in the cassette holder. 3. Press the record and pause buttons. 4. Set the tape selector to metal position. 5. Supply 1kHz signal from AF oscillator through ATT to LINE IN. 6. Adjust ATT so that input level is -20 dB below standard recording level. 7. At this time, LINE OUT level indicates 0.066 V. 8. Record 1kHz and 13 kHz signals. 9. Playback and express in dB the difference between output levels of 13kHz and 1kHz. 10. Make sure output level of 13 kHz is not within +1 ± 2 dB compared with output level of 1kHz. 11. If measured value is not within +1 ± 2 dB, adjust VR13 (L-CH only).  <p style="text-align: right;">Fig. 20</p> <p>B. Adjustment of normal tape</p> <ol style="list-style-type: none"> 12. Set the tape selector to normal position (Test tape QZZCRA). 13. Change test tape to normal tape (QZZCRA). 14. Press the record and playback buttons. 15. Record 1kHz and 8kHz signals. 16. Playback and express in dB the difference between output levels of 8 kHz and 1kHz. 17. Make sure output level of 8 kHz is not within +2 ± 2 dB compared with output level of 1 kHz. 18. If measured value is not within +2 ± 2 dB, adjust VR12 (L-CH), VR14 (R-CH). <p>C. Adjustment of Fe-Cr tape and CrO₂ tape</p> <ol style="list-style-type: none"> 19. Set the tape selector to Fe-Cr position. 20. Change test tape to Fe-Cr tape (QZZCRY). 21. Press the record and playback buttons. 22. Record 1kHz and 8kHz signals. 23. Playback and express in dB the difference between output levels of 8 kHz and 1 kHz. 24. Make sure output level of 8 kHz is not within +1 ± 1 dB, compared with output level of 1 kHz. 25. If measured value is not within +1 ± 1 dB, adjust VR15. 26. Set the tape selector to CrO₂ position. 27. Change test tape to CrO₂ tape (QZZCRX). 28. Make the same measurements and adjustments described in steps 21 to 24 above. 29. If measured value is not within +1 ± 1 dB, adjust VR16.  <p style="text-align: right;">Fig. 21</p>

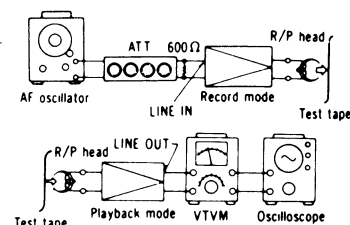
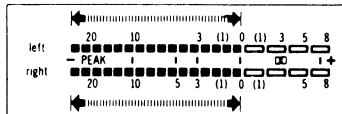
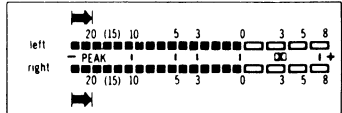
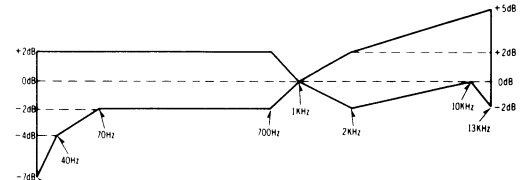
ITEM	MEASUREMENT & ADJUSTMENT
	<p>Measurement</p> <ol style="list-style-type: none"> 1. Test equipment connection is shown in fig. 21. 2. Place UNIT into record mode. 3. Read voltage on VTVM and calculate bias current by following formula. $\text{Bias current (A)} = \frac{\text{Value read on VTVM (V)}}{10 (\Omega)}$ <div style="border: 1px solid black; padding: 5px; margin: 10px auto; width: fit-content;"> <p>Standard value: around 600μA (Metal position), around 310μA (Normal position), around 350μA (Fe-Cr position), around 420μA (CrO₂ position)</p> </div>
<p>Ⓚ Overall gain</p> <p>Condition:</p> <ul style="list-style-type: none"> * Record/playback mode * Input level control ... MAX * Standard input level: <ul style="list-style-type: none"> MIC..... -72 \pm 3 dB LINE IN ... -24 \pm 3 dB DIN -72 \pm 3 dB * Bias adjustment control ... Center * Output level control ... MAX <p>Equipment:</p> <ul style="list-style-type: none"> * VTVM * AF oscillator * ATT * Oscilloscope * Test tape (reference blank tape) <ul style="list-style-type: none"> ... QZZCRA for Normal ... QZZCRX for CrO₂ ... QZZCRY for Fe-Cr ... QZZCRZ for Metal 	<ol style="list-style-type: none"> 1. Test equipment connection is shown in fig. 22. 2. Place UNIT into record mode. 3. Supply 1kHz signal (-24 dB) from AF oscillator, through ATT to LINE IN. 4. Adjust ATT until monitor level at LINE OUT becomes 0.66 V. 5. Using test tape, make recording. 6. Playback recorded tape, and measure the output level at LINE OUT on VTVM. <div style="border: 1px solid black; padding: 5px; margin: 10px auto; width: fit-content;"> <p>Standard value: 0.66 \pm 0.05 V</p> </div> <ol style="list-style-type: none"> 7. If measured value is not within standard, adjust the following VR. <ul style="list-style-type: none"> Normal VR9 (L-CH), VR10 (R-CH) Fe-Cr VR7 (L-CH), VR8 (R-CH) CrO₂ VR5 (L-CH), VR6 (R-CH) Metal VR801 (L-CH), VR802 (R-CH)  <p style="text-align: center;">Fig. 22</p>
<p>Ⓛ Fluorescent meter</p> <p>Condition:</p> <ul style="list-style-type: none"> * Record mode * Input level control ... MAX * Output level control ... MAX * Tape selectors ... Normal position <p>Equipment:</p> <ul style="list-style-type: none"> * VTVM * AF oscillator * ATT 	<ol style="list-style-type: none"> 1. Test equipment connection is shown in fig. 23. 2. Set the meter function selector to the "bright" position. 3. Supply 1kHz signal (-24 dB) to the LINE IN jack, then press the record button. 4. Adjust the ATT so that the output level at LINE OUT jack becomes 0.66 V (= standard input level). 5. Adjustment at "0 dB": <ol style="list-style-type: none"> A. Adjust VR303 (L-CH) and VR304 (R-CH) so that the Fluorescent meters show an illuminated indication up to "0 dB" when the input signal level is 0.9 dB higher than the standard input level. B. Then confirm that the Fluorescent meters show an illuminated indication up to "+1 dB" when the input signal level is 1 dB higher than the standard input level. 6. Adjustment at "-20 dB": <ol style="list-style-type: none"> A. Adjust VR301 (L-CH) and VR302 (R-CH) so that the Fluorescent meters show an illuminated indication up to "-20 dB" when the input signal level is 15.1 dB lower than the standard input level. B. Then confirm that the Fluorescent meters show an illuminated indication up to "-15 dB" when the input signal level is 15 dB lower than the standard input level. 7. Repeat twice between steps 3 and 6 above.  <p style="text-align: center;">Fig. 23</p>  <p style="text-align: center;">Fig. 24</p>
<p>Ⓜ Overall frequency response</p> <p>Condition:</p> <ul style="list-style-type: none"> * Record/playback mode * Input level control ... MAX * Bias adjustment control ... Center 	<p>Note:</p> <p>Before measuring and adjusting, make sure of the playback frequency response (For the method of measurement, please refer to the playback frequency response).</p> <ol style="list-style-type: none"> 1. Test equipment connection is shown in fig. 22. 2. Load reference blank test tape and place UNIT into record mode. <div style="text-align: center;"> <p>Overall frequency response chart (Normal)</p>  </div> <p style="text-align: center;">Fig. 25</p>

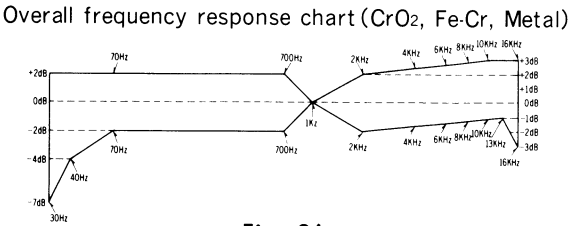
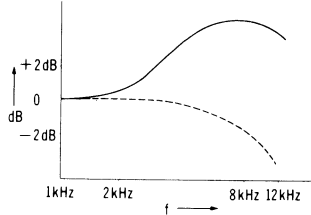
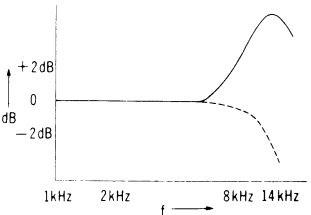
ITEM	MEASUREMENT & ADJUSTMENT
<p>Equipment:</p> <ul style="list-style-type: none"> * VTVM * AF oscillator * ATT * Test tape (reference blank tape) <ul style="list-style-type: none"> ... QZZCRA for Normal ... QZZCRX for CrO₂ ... QZZCRY for Fe-Cr ... QZZCRZ for Metal 	<ol style="list-style-type: none"> 3. Supply 1kHz signal from AF oscillator through ATT to LINE IN. 4. Adjust ATT so that input level is -20 dB below standard recording level (standard recording level = 0 VU). 5. At this time, LINE OUT level indicates 0.066 V. 6. Record each frequency 30Hz, 40Hz, 70Hz, 700Hz, 1kHz, 2kHz, 7kHz, 10kHz and 13.5kHz (16kHz for CrO₂, Fe-Cr and Metal) at the same level. 7. Playback and express in dB the difference between playback output level of each frequency based on playback output level of 1kHz. 8. Make sure that the measured value is within the range specified in the overall frequency response chart. <div style="text-align: right; margin-top: 10px;">  <p>Overall frequency response chart (CrO₂, Fe-Cr, Metal)</p> <p>Fig. 26</p> </div> <p>Adjustment-1</p> <ol style="list-style-type: none"> 1. When the frequency response between the middle and high frequency range becomes higher than the standard value, as shown by the solid line in fig. 27 increase, refer to bias current adjustment. 2. When it becomes lower, as shown by dotted line, refer to bias current adjustment. <div style="text-align: right; margin-top: 10px;">  <p>Fig. 27</p> </div> <p>Note:</p> <ol style="list-style-type: none"> 1. For adjustment when the bias current is lower than the standard value use the procedure indicated in adjustment 2, because reducing the bias current beyond this point may worsen the distortion factor. 2. For the method of bias current measurement, refer to "Bias current adjustment" on page 5. <p>Adjustment-2</p> <p>When the frequency response is flat in the middle frequency range and makes a sharp rise or drop in the high frequency range, as shown in fig. 28, adjust by turning the following peaking coils.</p> <ul style="list-style-type: none"> Normal L3 (L-CH), L4 (R-CH) Fe-Cr L5 (L-CH), L6 (R-CH) CrO₂ L7 (L-CH), L8 (R-CH) Metal L801 (L-CH), L802 (R-CH) <div style="text-align: right; margin-top: 10px;">  <p>Fig. 28</p> </div>
<p>N Dolby NR circuit</p> <p>Condition:</p> <ul style="list-style-type: none"> * Record mode * Input level control ... MAX <p>Equipment:</p> <ul style="list-style-type: none"> * VTVM * AF oscillator * ATT * Oscilloscope 	<ol style="list-style-type: none"> 1. Place UNIT into record mode, set the Dolby NR switch to OUT position and supply to LINE IN to obtain -34.5 dB at TP9 (L-CH), TP10 (R-CH) (frequency 5 kHz). 2. Confirm that the value at IN position is 8 dB greater than the value at OUT position of Dolby NR switch. 3. When it is not in condition above, adjust as follows. 4. Set the VR201 to maximum. 5. Set the Dolby NR switch to IN position. 6. At this time adjust VR202 so that the reading of VTVM becomes 10 dB greater than the value in step (1) above. 7. Adjusting VR201 make the reading of VTVM becomes 2 dB smaller than the value obtained through the adjustment in step (6) above.

SCHEMATIC DIAGRAM

Main Amp Section

TR1 2SA721 TR2 2SC1327

TR204 2SC945

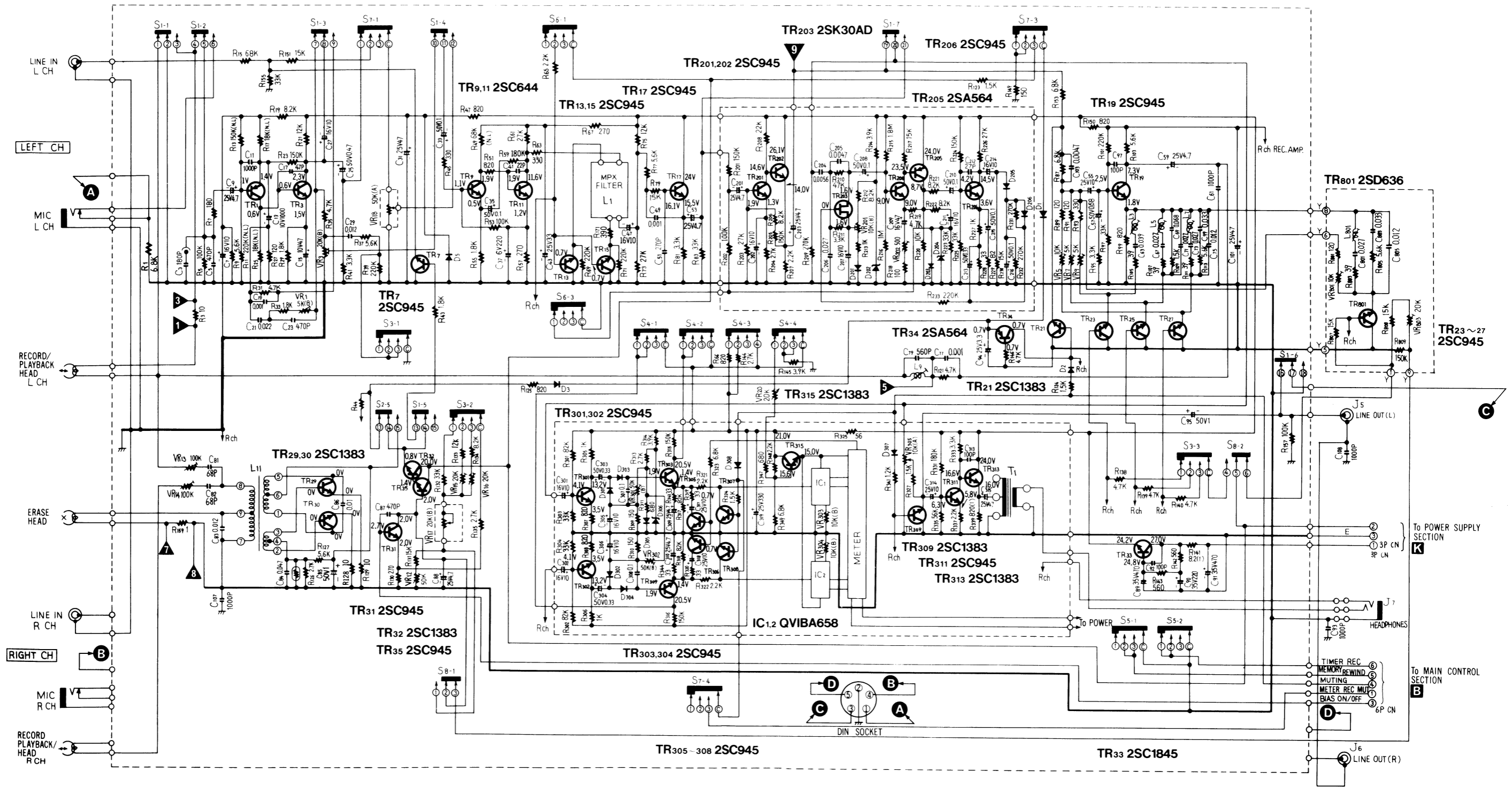

NOTE:

- S1-1~S1-7, S2-1~S2-7 Record/playback select switch (shown in playback position).
- S3-1~S3-4 Tape select switch (1...normal, 2...Fe-Cr, 3...CrO2).
- S4-1~S4-4 Meter select switch (1...peak/bright, 2...peak/dim, 3...VU/dim).
- S5-1, S5-2 Function switch (1...memory rew, 2...off, 3...timer rec).
- S6-1~S6-4 Dolby NR select switch (1...Dolby "OUT", filter "OUT", 2...Dolby "IN", filter "IN", 3...Dolby "IN", filter "OUT").
- S7-1~S7-4 Input select switch (1...mic, 2...line in, 3...rec mute).
- S8-1, S8-2 Tape select switch (for metal tape).
- VR1, 2 Playback equalizer adjustment VR.
- VR3, 4 Playback level adjustment VR.
- VR5, 6 Standard recording level adjustment VR (for CrO2 tape).
- VR7, 8 Standard recording level adjustment VR (for Fe-Cr tape).
- VR9, 10 Standard recording level adjustment VR (for normal tape).

- VR12 Bias current adjustment VR (for normal tape).
- VR13 Bias current adjustment VR (for metal tape).
- VR14 Bias current adjustment VR (for normal tape).
- VR15 Bias current adjustment VR (for Fe-Cr tape).
- VR16 Bias current adjustment VR (for CrO2 tape).
- VR17 Bias current adjustment control.
- VR18, 19 Input level control.
- VR20 Meter brightness adjustment control.
- VR201, 202 Dolby NR adjustment VR.
- VR301, 302 Fluorescent level meter adjustment VR (for -20dB indication).
- VR303, 304 Fluorescent level meter adjustment VR (for 0dB indication).
- VR305, 306 Output level control.
- VR801, 802 Standard recording level adjustment VR (for metal tape).

- VR803 Erase current adjustment VR (for metal tape).
- L3, 4 Recording equalizer adjustment coil (for normal tape).
- L5, 6 Recording equalizer adjustment coil (for Fe-Cr tape).
- L7, 8 Recording equalizer adjustment coil (for CrO2 tape).
- L801, 802 Recording equalizer adjustment coil (for metal tape).
- Resistance are in ohms (Ω), 1/4 watt unless specified otherwise. K = 1,000Ω.
- Capacity are in microfarads (μF) unless specified otherwise. P = Pico-farads.
- All voltage values shown in circuitry under no signal condition and record mode with volume control at minimum position. For measurement, use VTVM.

SPECIFICATIONS

* Input level control... MAX	
* Output level control... MAX	
Playback S/N ratio Test tape... QZZCFM	Greater than 47 dB
Overall distortion Test tape ... QZZCRA for Normal ... QZZCRX for CrO2 ... QZZCRY for Fe-Cr ... QZZCRZ for Metal	Less than 3%
Overall S/N ratio Test tape... QZZCRA	Greater than 45 dB (without NAB filter)

ADJUSTMENT PARTS LOCATION

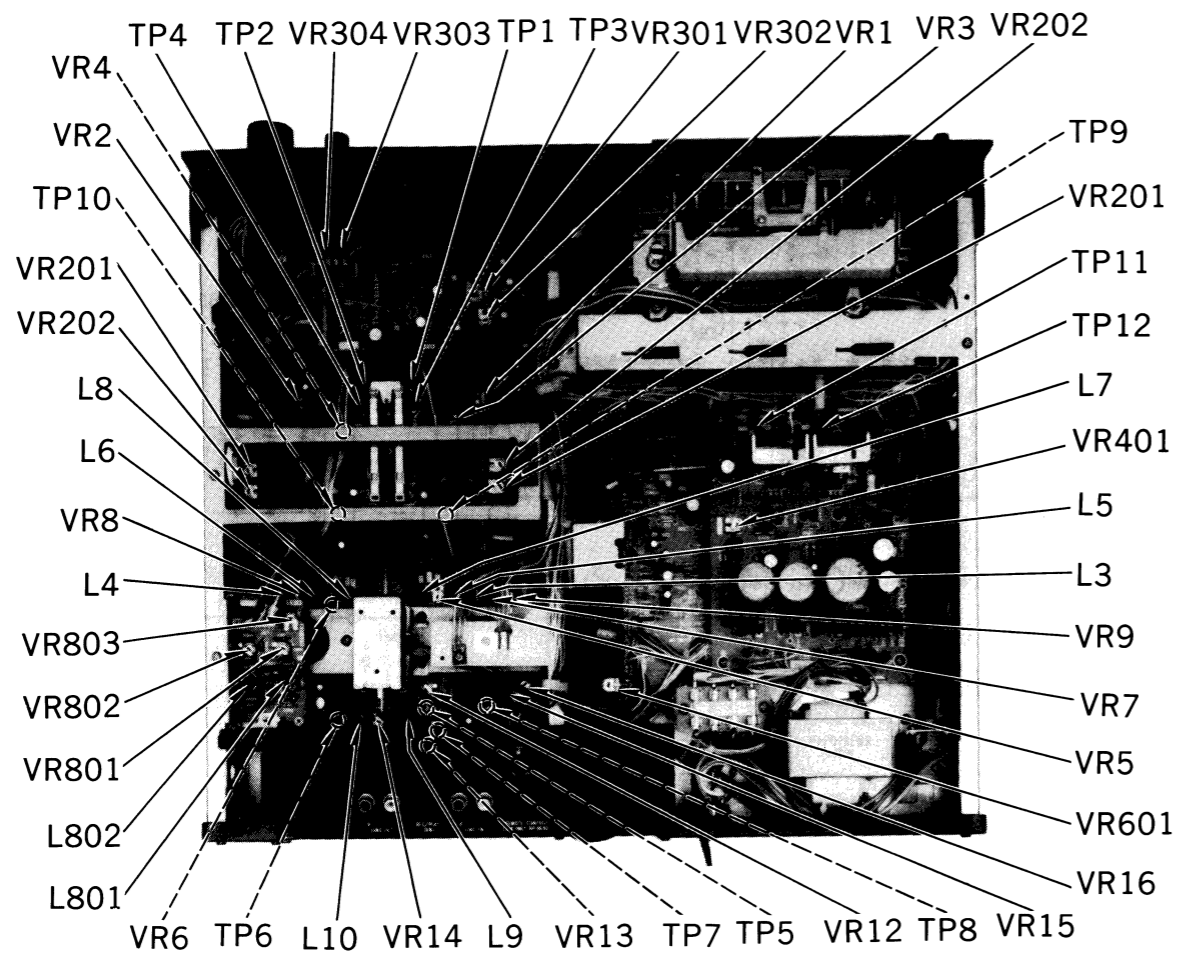

CABINET PARTS

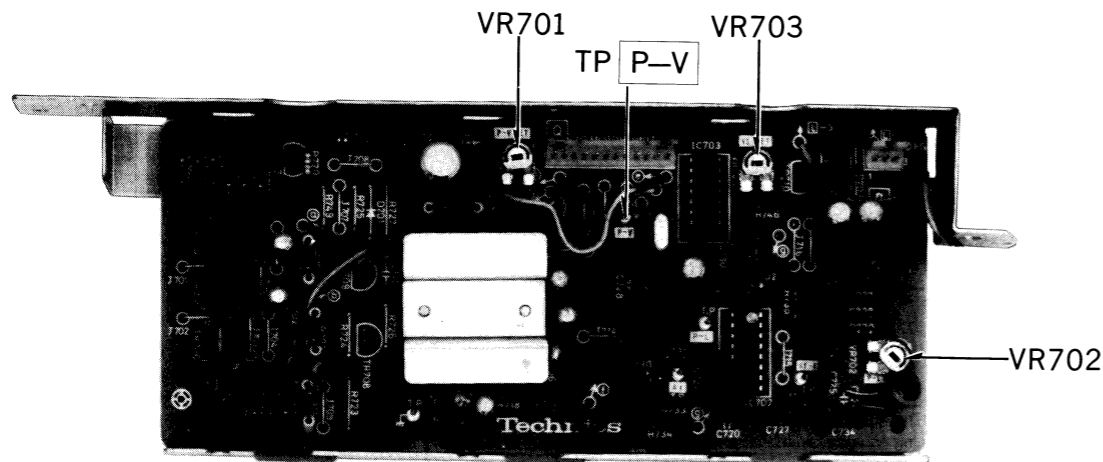
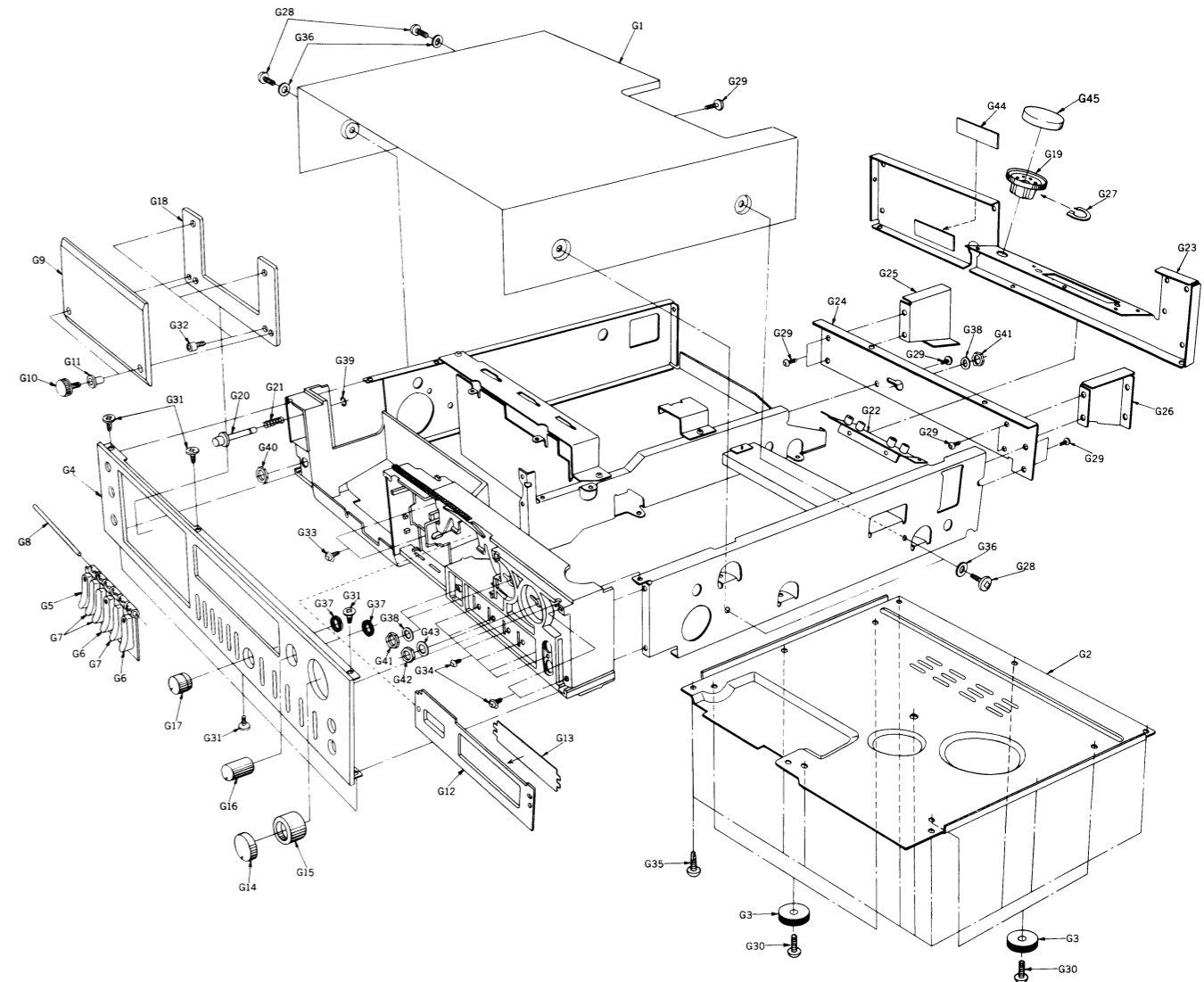

Fig. 29

NOTE: Δ indicates that only parts specified by the manufacturer be used for safety.

Ref. No.	Part No.	Part Name & Description	Ref. No.	Part No.	Part Name & Description	Ref. No.	Part No.	Part Name & Description	Ref. No.	Part No.	Part Name & Description
CABINET PARTS											
G1	QGC1102 "Black Type" QGC1116 "Silver Type"	Case Cover	G13	QGL1130	Meter Cover-B	G21	QBC1216	Eject Button Spring	G43	XWS9AW	Washer 9 ϕ
G2	QGC1089	Bottom Cover	G14	QYT0465 "Black Type" QYT0494 "Silver Type"	Volume Knob-A Assembly	G22	QEJ5002S	Jack Board Assembly	G44	QGS2723	Name Plate
G3	QKA1076	Rubber Foot	G15	QYT0466A "Black Type" QYT0495 "Silver Type"	Volume Knob-B Assembly	G23	QMK1725	Back Cover-A	G45	QGS2725	Remote Cap
G4	QYP0886 "Black Type" QYP0888 "Silver Type"	Front Panel Assembly	G16	QYT0456 "Black Type" QYT0497 "Silver Type"	Volume Knob Assembly	G24	QMA3305	Back Cover-B	*For All European areas except United Kingdom. *For United Kingdom.		
G5	QXB0528	Control Button (REC)	G17	QYT0559	Volume Knob-C Assembly (bias adjust)	G25	QMA3306	Back Cover Holder-R			
G6	QXB0529	Control Button (PLAY, PAUSE)	G18	QGK2947 "Black Type" QGK2947S "Silver Type"	Cassette Lid	G26	QMA3307	Back Cover Holder-L	*For All European areas except United Kingdom. *For United Kingdom.		
G7	QGO1416	Control Button (FF, REW, STOP)	G19	QJS0803X	Remote Control Socket	G27	QMA3445	Socket Angle			
G8	QMN2266	Button Shaft	G20	QXB0527A "Black Type" QXB0577 "Silver Type"	Eject Button Assembly	G28	XSB4+8BVS	Screw \oplus 4x8	*For All European areas except United Kingdom. *For United Kingdom.		
G9	QGK2804	Cassette Lid	G21	QXUC25FT		G29	XSN4+6S	Tapping Screw \oplus 3x8			
G10	QHJ1272 "Black Type" QHJ1280 "Silver Type"	Cassette Lid Holder	G22	QXNQ1051		G30		Screw \oplus 4x6	*For All European areas except United Kingdom. *For United Kingdom.		
G11	QBG1551	Rubber Cushion	G23	QXNTN3+6B		G31	XSS3+8S	Screw \oplus 3x8			
G12	QKJ0246 "Black Type" QKJ0313 "Silver Type"	Meter Cover-A	G24	QXNSN3+6BVS		G32	XVE26C4FZ "Black Type" XVE26A4FN "Silver Type"	Screw	*For All European areas except United Kingdom. *For United Kingdom.		
ACCESSORIES											
PACKINGS											
ACCESSORIES											
A1	RP023A	Connection Cord	P1	QPN3904	Inside Carton	G33	XTN3+6B	Tapping Screw \oplus 3x6	P2	QPA0376	Inner Cushion-A (Left)
A2	QFTC30S011TZ	Demonstration Tape	P3	QPA0377	Inner Cushion-A (Right)	G34	XSN3+6BVS	Screw \oplus 3x6	P4	QPA0378	Inner Cushion-B (Left)
A3	QQT2671	Instruction Book	P5	QPA0379	Inner Cushion-B (Right)	G35	XTN4+8B	Tapping Screw \oplus 4x8	P6	QPA0380	Spacer (Bottom Side)
A3	QQT2673		P7	QPA0381	Spacer (Top Side)	G36	XWG4FZ	Flat Washer 4 ϕ	P8	XZB50X65A04	Poly Bag
PACKINGS											

SCHEMATIC DIAGRAM

Main Amp Section

TR1 2SA721 TR2 2SC1327

TR204 2SC945

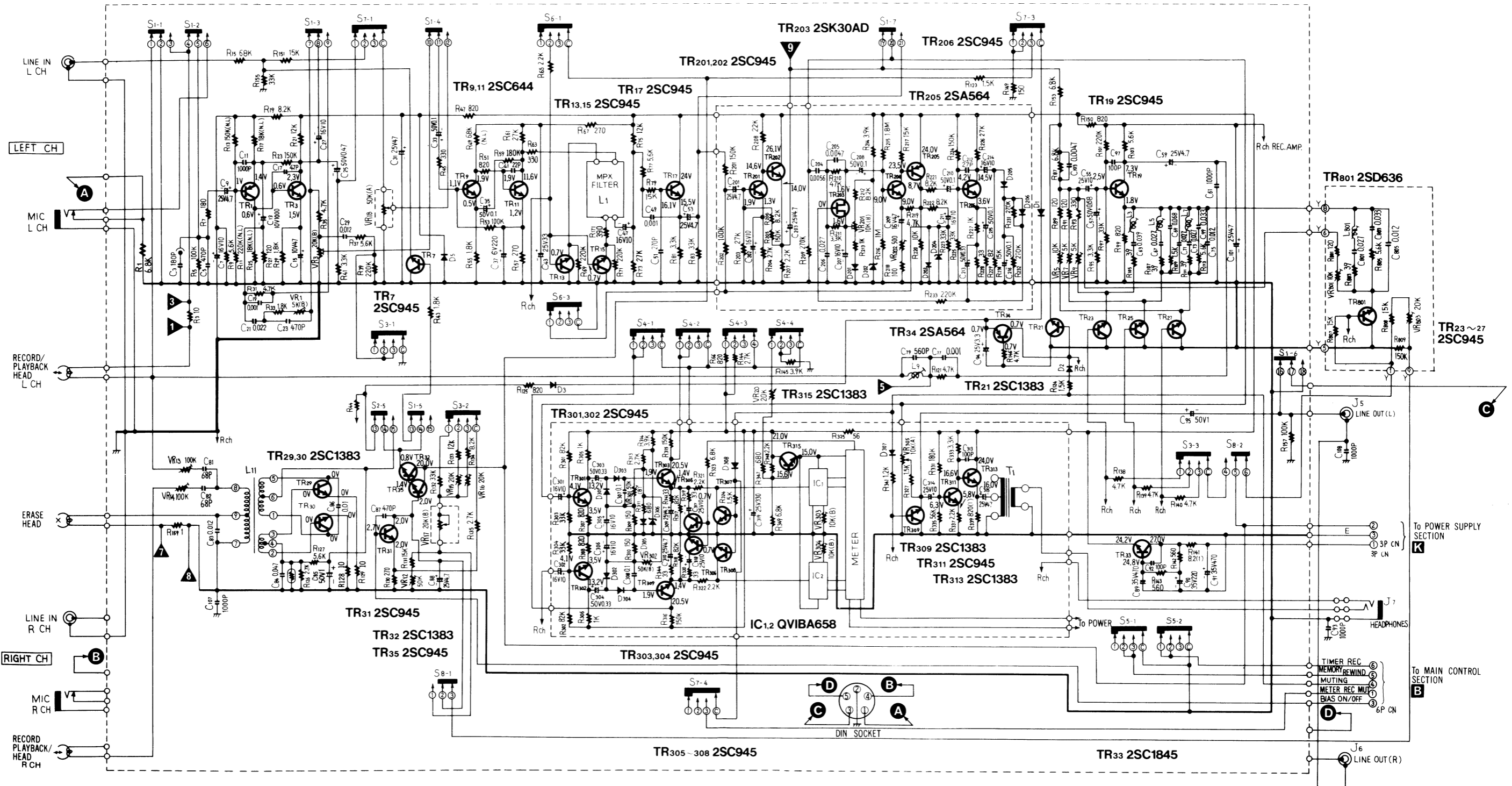

NOTE:

- S1-1~S1-7, S2-1~S2-7 Record/playback select switch (shown in playback position).
- S3-1~S3-4 Tape select switch (1...normal, 2...Fe-Cr, 3...CrO2).
- S4-1~S4-4 Meter select switch (1...peak/bright, 2...peak/dim, 3...VU/dim).
- S5-1, S5-2 Function switch (1...memory rew, 2...off, 3...timer rec).
- S6-1~S6-4 Dolby NR select switch (1...Dolby "OUT", filter "OUT", 2...Dolby "IN", filter "IN", 3...Dolby "IN", filter "OUT").
- S7-1~S7-4 Input select switch (1...mic, 2...line in, 3...rec mute).
- S8-1, S8-2 Tape select switch (for metal tape).
- VR1, 2 Playback equalizer adjustment VR.
- VR3, 4 Playback level adjustment VR.
- VR5, 6 Standard recording level adjustment VR (for CrO2 tape).
- VR7, 8 Standard recording level adjustment VR (for Fe-Cr tape).
- VR9, 10 Standard recording level adjustment VR (for normal tape).

- VR12 Bias current adjustment VR (for normal tape).
- VR13 Bias current adjustment VR (for metal tape).
- VR14 Meter current adjustment VR (for normal tape).
- VR15 Bias current adjustment VR (for Fe-Cr tape).
- VR16 Bias current adjustment VR (for CrO2 tape).
- VR17 Bias current adjustment control.
- VR18, 19 Input level control.
- VR20 Meter brightness adjustment control.
- VR201, 202 Dolby NR adjustment VR.
- VR301, 302 Fluorescent level meter adjustment VR (for -20dB indication).
- VR303, 304 Fluorescent level meter adjustment VR (for 0dB indication).
- VR305, 306 Output level control.
- VR801, 802 Standard recording level adjustment VR (for metal tape).

- VR803 Erase current adjustment VR (for metal tape).
- L3, 4 Recording equalizer adjustment coil (for normal tape).
- L5, 6 Recording equalizer adjustment coil (for Fe-Cr tape).
- L7, 8 Recording equalizer adjustment coil (for CrO2 tape).
- L801, 802 Recording equalizer adjustment coil (for metal tape).
- Resistance are in ohms (Ω), 1/4 watt unless specified otherwise. K = 1,000 Ω .
- Capacity are in microfarads (μF) unless specified otherwise. P = Pico-farads.
- All voltage values shown in circuitry under no signal condition and record mode with volume control at minimum position. For measurement, use VTVM.

SPECIFICATIONS * Input level control... MAX * Output level control... MAX

Playback S/N ratio Test tape... QZZCFM	Greater than 47 dB
Overall distortion Test tape ... QZZCRA for Normal ... QZZCRX for CrO2 ... QZZCRY for Fe-Cr ... QZZCRZ for Metal	Less than 3%
Overall S/N ratio Test tape... QZZCRA	Greater than 45 dB (without NAB filter)

CIRCUIT BOARD

Main Amp

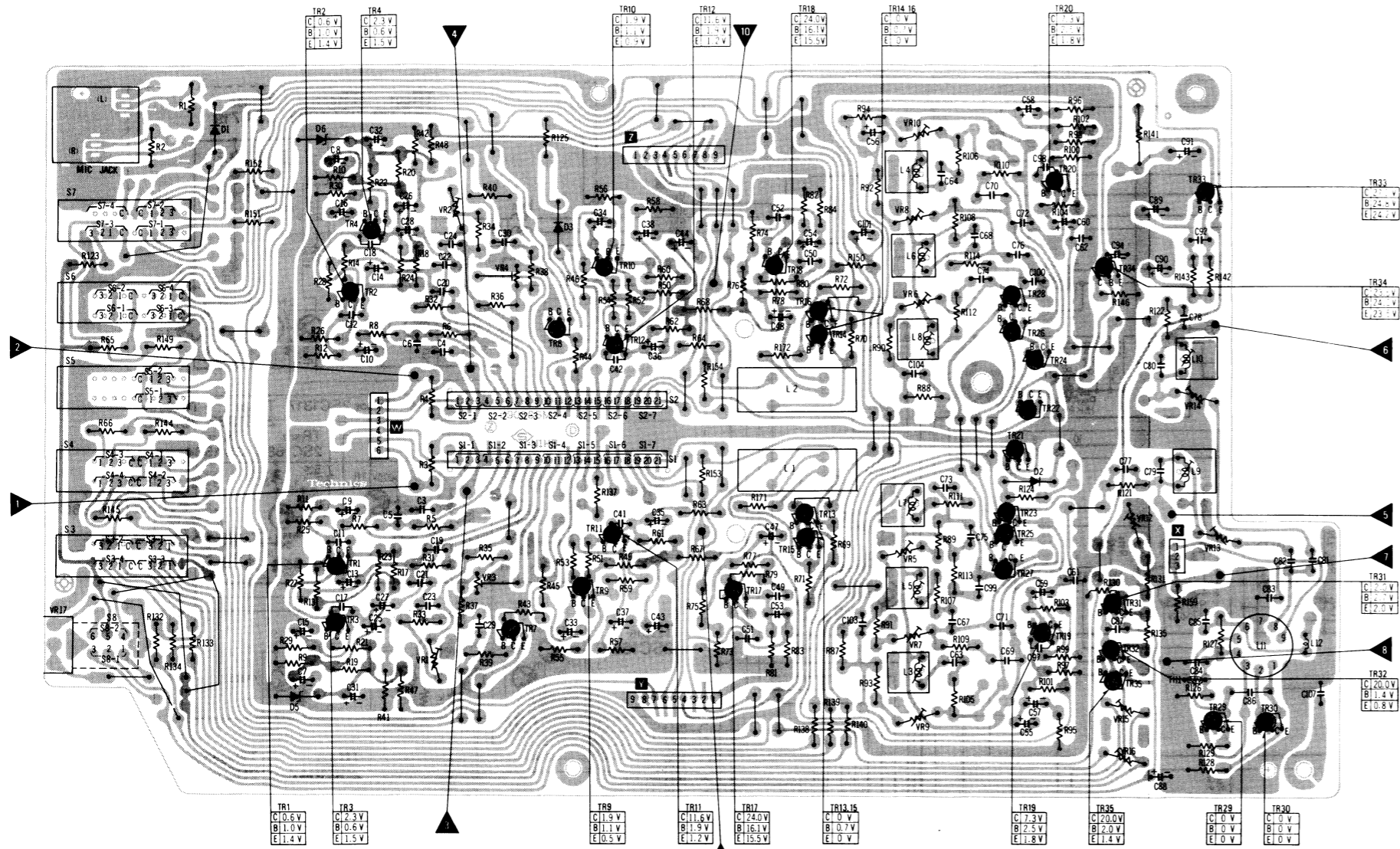

Output

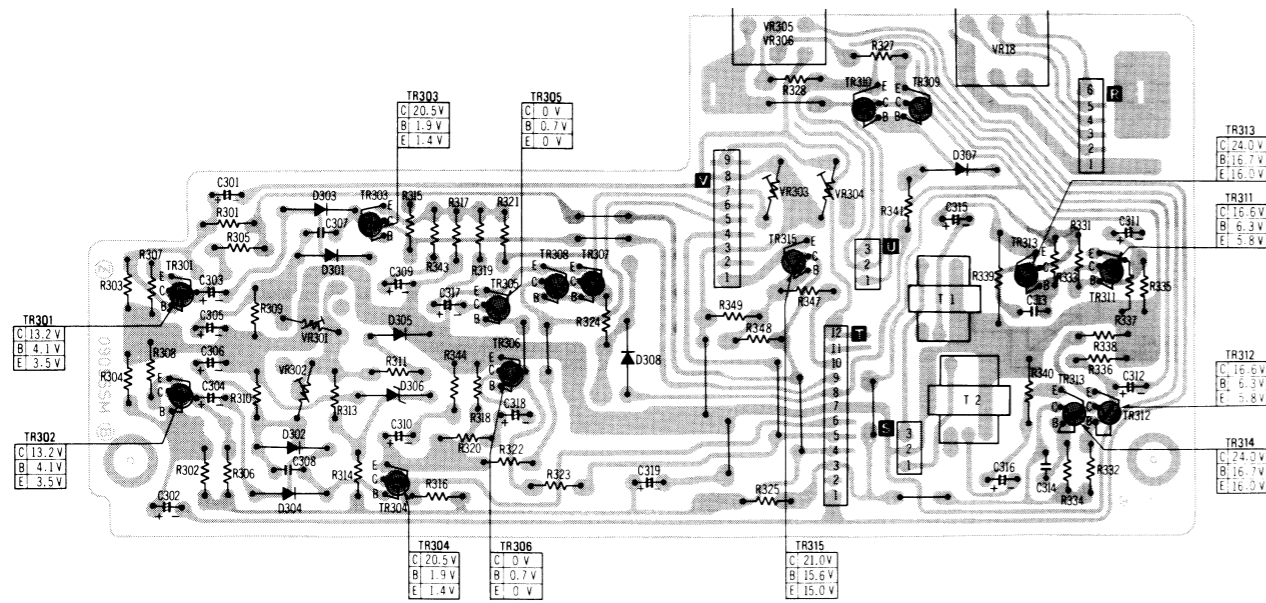

Equalizer

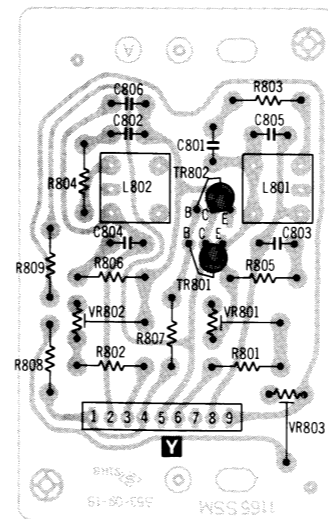

Dolby

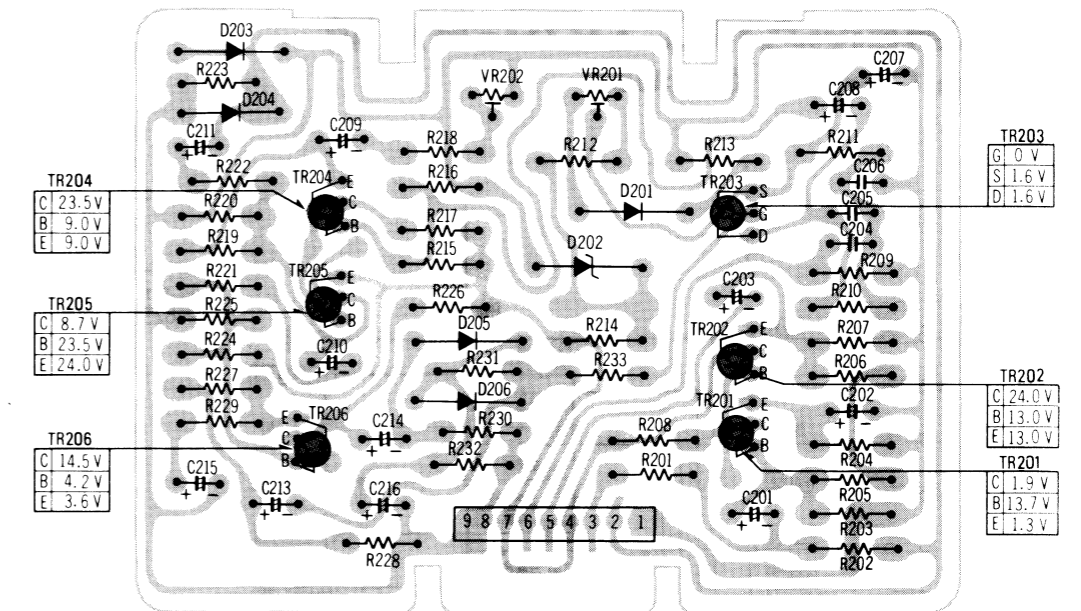

FL Meter

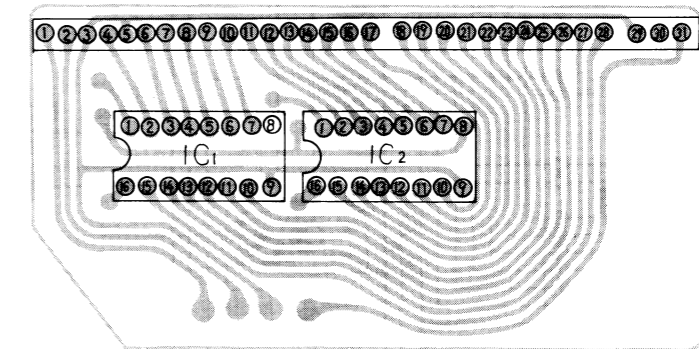

Headphones Jack

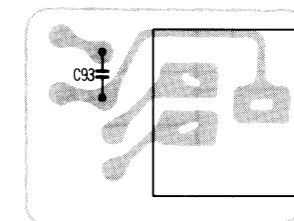

Jack

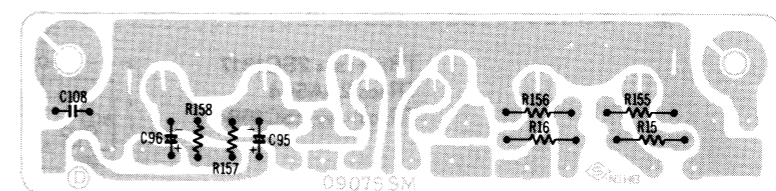

NOTE:

The circuit shown in red on the conductor is B circuit. Values indicated in are DC voltage between the chassis and electrical parts.

SCHEMATIC DIAGRAM Main Control Section

Ref. No.	Part No.	Ref. No.	Part No.	Ref. No.	Part No.	Ref. No.	Part No.
C41, 42	ECCD1H220K	C509	ECEA1HS100	Tr309, 310	2SC1383	D411	Δ RVD10DC4
C43, 44	ECEA1VS330	C510	ECEA16Z10			D412	Δ RVD10DC4R
		C511	ECEA50Z1	Tr311, 312		D413	SM112
C47, 48	ECEA1HS100	C512	ECEA16Z10			D414	Δ RVD10DC4R
C49, 50	ECQM05102KZ	C513	ECEA50Z2R2	Tr313, 314, 315		D414	MV121
C51, 52	ECCD1H271K	C514	ECEA16N10			D415	Δ RVD10DC4
C53, 54	ECEA1JS4R7	C515	ECEA1HS100	D501, 502, 503, 504, 505, 506, 507, 508			
C55, 56	ECEA1HS100	C517, 518	ECKD1H472KB	Tr401	2SC1226		
C57, 58	ECEA50ZR68			Tr402, 403, 404, 405		D509	MA150 OA91
C59, 60	ECEA2SMAR7						
C61, 62	ECKD1H102K	C519	ECEA1AS221	Tr406	2SA564		
C63, 64	ECQM05393KZ	C521	ECKD1H103ZF	Tr407	2SD389	D510, 511, 513, 514	MA150
C67, 68	ECQM05273KZ	C522	ECEA16Z10	Tr408, 409		D515	SM112
		C523	ECEA50Z1			D516	MV121
C69, 70	ECQM05683KZ	C524, 525		Tr501, 502, 503		D517	MA150
C71, 72, 73, 74						D550, 551, 552	
C75, 76	ECQM05273KZ	C526	ECEA1HS100	Tr504	2SC1317		
C77, 78	ECQM05123KZ	C530	ECEA1CS471	Tr505	2SC1684		
C79, 80	ECQM05102KZ	C590	ECEA50ZR47	Tr506, 507, 508, 509, 510, 511, 512, 513, 514, 515, 516, 518, 519, 520, 521, 522		D590	MA150
C81, 82	ECQS1561JZ	C601, 602	ECEA1CS330			D591	JS2473T
C83	ECCD1H680K	C603, 604, 605	ECEA16Z10	Tr523	2SC1684	D601, 602, 603, 604, 605	MA150
C84	ECQF4123KZ					D606, 608	OA90M SM112
C85	ECQM05473KZ						
C86	ECEA50Z1						
	ECQF4103KZH					D609	MA1120
C87	ECKD1H471K	C606	ECEA16Z33	Tr601	2SA719	D610	OA90M
C88	ECEA1JS4R7	C610	ECEA50Z2R2	Tr602	2SC1846	D611	SM112
C89	ECEA1VS471	C701, 702, 703	ECEA1VS3R3	Tr603	2SA719	D702	MA150
C90	ECEA1VS221					D703	MA1120
C91	ECEA1VS471						
C92	ECCD1H101K	C704	ECEA50ZR47	Tr606	2SC1684		
C93	ECCD1H102KB	C705, 706, 707		Tr607	2SC1317		
C94	ECEA25Z3R3	C708	ECEA50Z2R2	Tr608	2SC1684		
C95, 96	ECEA50Z1	C709	ECQM05473KZ	Tr609, 610, 611			
C97, 98	ECCD1H101K	C710	ECQM05393KZ	Tr612	2SC1684		
		C712	ECFDD104KXY	Tr613	2SC1684		
		C713	ECEA25Z100				
C99, 100	ECQM05333KZ	C714	ECQM05393KZ	Tr614	2SA886		
C101	ECEA1ES470	C715	ECQM05683KZ	Tr615	2SA564		
C103, 104		C716	ECQM05104KZ	Tr616	2SC1684		
		C717	ECQM05103KZ	Tr617	2SA886		
C107, 108	ECCD1H102K	C718	ECQM05223KZ	Tr618	2SC1684		
C201x2	ECEA25Z4R7	C719	ECEA50Z2R2	Tr619	2SC1847		
C202x2	ECEA1HS100	C720	ECQM05562KZ	Tr620	2SC1684		
C203x2	ECEA25Z4R7	C721	ECQM05153KZ	Tr621	2SC1847		
C204x2	ECQM05562KZ	C722	ECQM05562KZ	Tr622	2SC1684		
C205x2	ECQM05472KZ	C723	ECCD1H471KB	Tr623	2SC1847		
C206x2	ECQM05273KZ	C724	ECQM05123KZ	Tr624	2SC1406		
		C725	ECQM05182KZ	Tr701, 702, 703			
C207x2	ECEA1HS100	C726	ECQS1682JZ	Tr707	2SC1846		
C208x2	ECEA50MR1	C727	ECQM0523KZ	Tr704, 705, 706			
C209x2	ECEA1ES470	C728, 729					
C210x2	ECEA50Z1						
C211x2	ECEA1HS100	C730	ECCD1H220KC	Tr707	2SC1318		
C212x2	ECCD1H270KC	C731, 732, 733	ECQM05562KZ	Tr710	2SC1383		
C213x2	ECEA50ZR33			Tr801, 802			
C214x2	ECEA1HS100	C734	ECEA1CS330				
C215x2	ECEA50Z1	C801, 802	ECQM05332KZ				
C216x2	ECEA50Z1						
C301, 302	ECEA1HS100	C803, 804	ECQM05273KZ				
C303, 304	ECEA50ZR33	C805, 806	ECQM05123KZ				
C305, 306	ECEA1HS100						
C307, 308	ECFWD104MXY	Z401, 402					
C309, 310	ECEA25Z4R7						
C311, 312	ECEA1HS100						
C313, 314	ECCD1H101K						
C315, 316	ECEA1ES470						
C317, 318	ECEA1HS100						
C319	ECEA1ES331						
C401	Δ ECET35R2200S						
C402	ECEA1VS101						
C404	ECEA1ES221						
C405	Δ ECET16R2200S						
C406	ECEA1HS100						
C407	ECCD1H102KB						
C408	Δ ECET25R4700S						
C409, 410							
C411	Δ ECEA1AS472						
C501, 502, 503, 504, 505, 506	ECQM05473KZ ECCD1H103ZF						
C507	ECEA1AS470						
C508	ECEA16Z10						

Ref. No.	Part No.	Part Name & Description
TRANSFORMERS		
T1, 2	QLT2D26X	Headphone Transformer
T401	Δ QLPA40EMX	Power Transformer *For United Kingdom.
T401	Δ QLPD29EMX	" *For All European areas except United Kingdom.
COILS		
L1, 2	QLM9Z4K	MPX Filter
L3, 4, 5, 6, 7, 8	QLQX0331W	3mH Coil
L9, 10	QLQX0731W	7mH Coil
L11	QLB0189	Bias Oscillator Coil
L12	QLQX2421Y	Choke Coil
L401, 601, 602	QLQZ1014D	"
L801, 802	QLQX0331W	Peaking Coil
SWITCHES		
S1, 2	QSS7203	Slide Switch (Record/Playback Selector)
S3, 4, 5, 6, 7	QST4311	Lever Switch
S401	Δ QSW2214	Push Switch (Power ON/OFF)
S402	Δ QSR1407	Voltage Select Switch
S501, 502, 503, 504, 505, 506	QSW1111H	Control Key Switch
S507, 508	QSM0067	Micro Switch
PILOT LAMPS		
PL501, 502, 503	XAMQ34S600W XAMQ41S400	Pilot Lamp "
PL505		"
FUSES		
F401	Δ XBAQ0009	Mini Fuse (800mA)
F402	Δ XBAQ0004	Mini Fuse (1AT)
F403, 404		
F405	Δ XBAQ0010	Mini Fuse (1.6AT)
F405	Δ XBAQ0006	Mini Fuse (315mA)

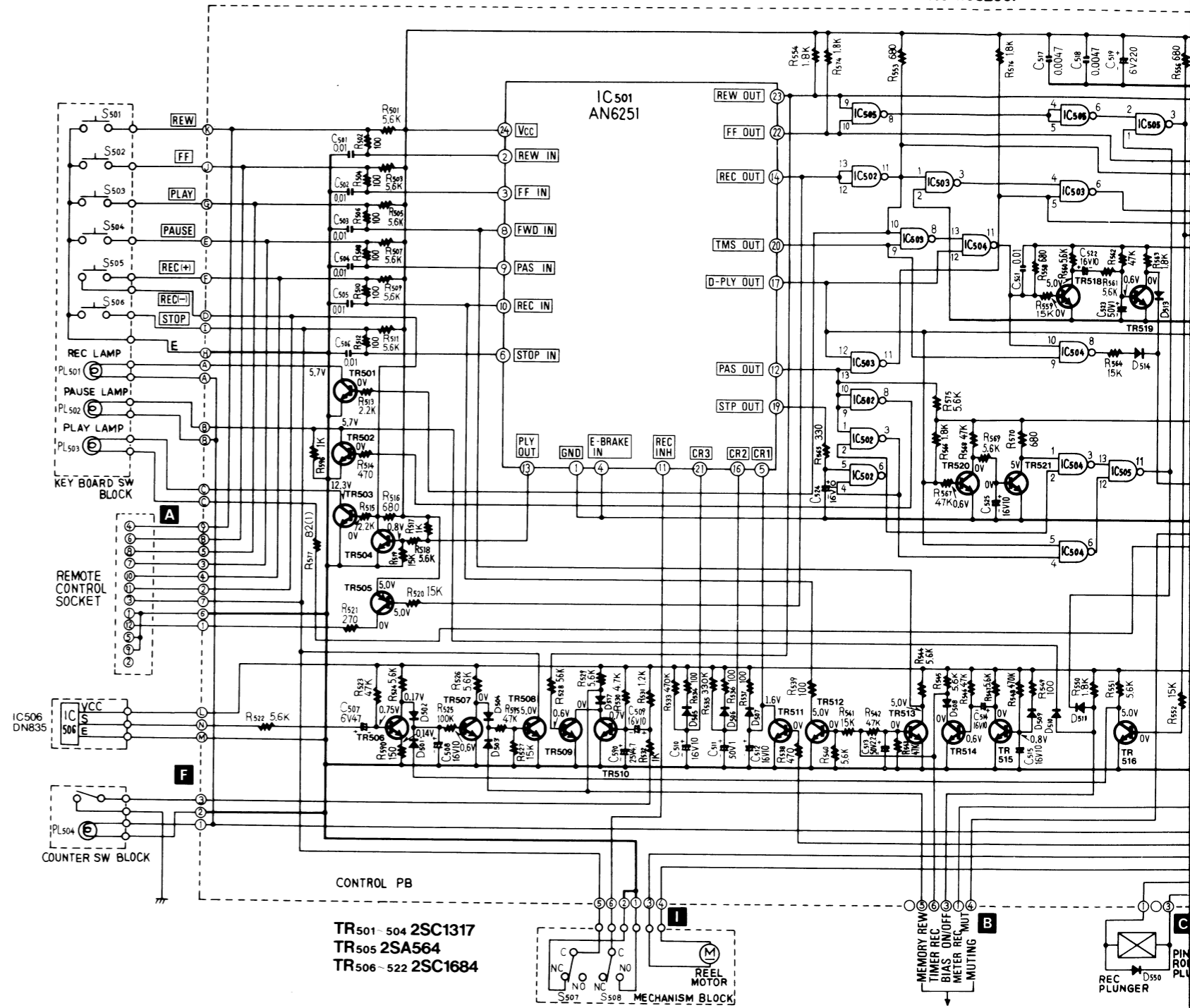

SCHEMATIC DIAGRAM

Main Control Section

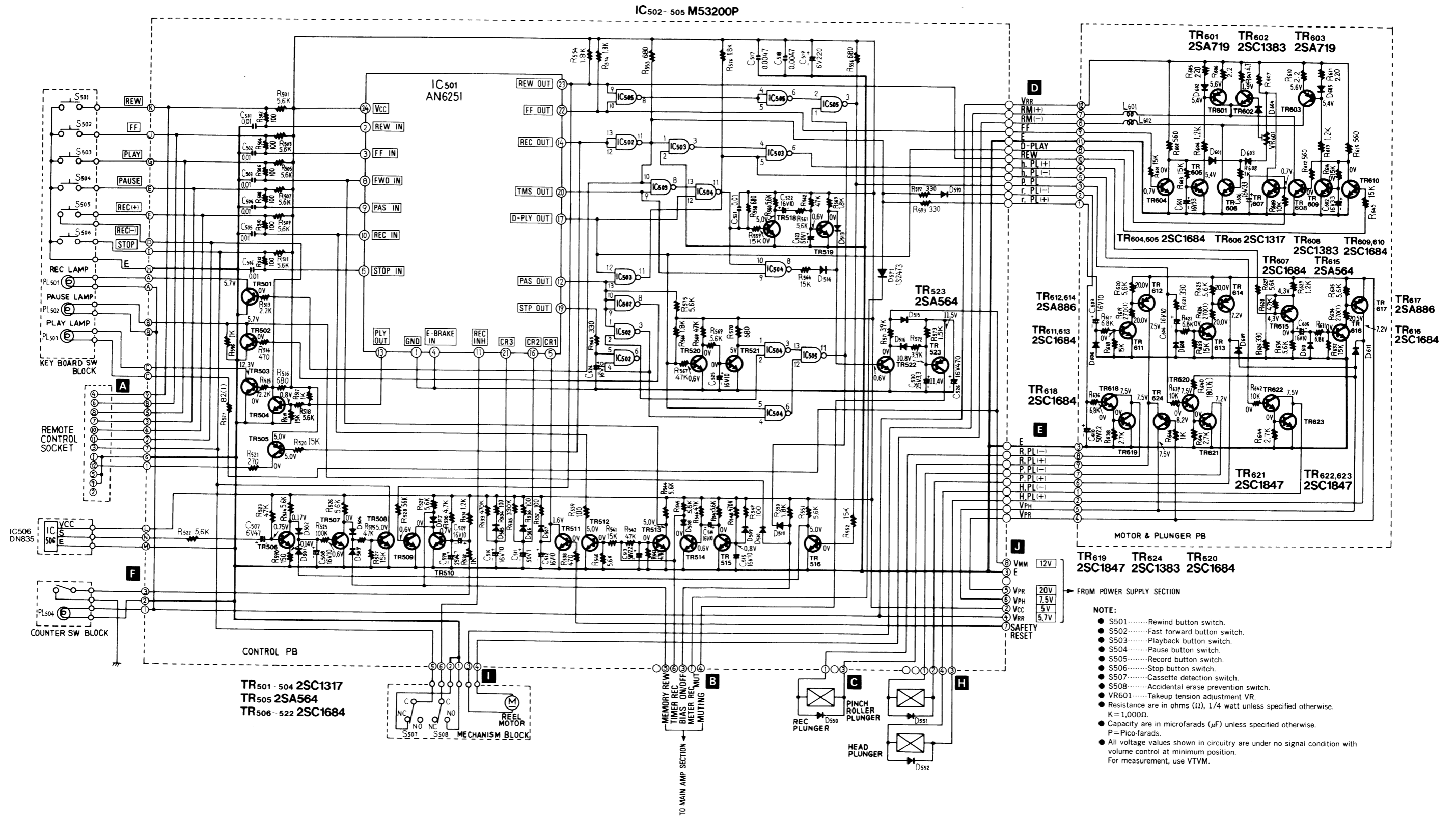

- NOTE:**
- S501.....Rewind button switch.
 - S502.....Fast forward button switch.
 - S503.....Play button switch.
 - S504.....Pause button switch.
 - S505.....Record button switch.
 - S506.....Stop button switch.
 - S507.....Cassette detection switch.
 - S508.....Accidental erase prevention switch.
 - VR601.....Takeup tension adjustment VR.
 - Resistance are in ohms (Ω), 1/4 watt unless specified otherwise. K=1,000 Ω .
 - Capacity are in microfarads (μ F) unless specified otherwise. P=Pico-farads.
 - All voltage values shown in circuitry are under no signal condition with volume control at minimum position. For measurement, use VTVM.

CIRCUIT BOARD

Main Control

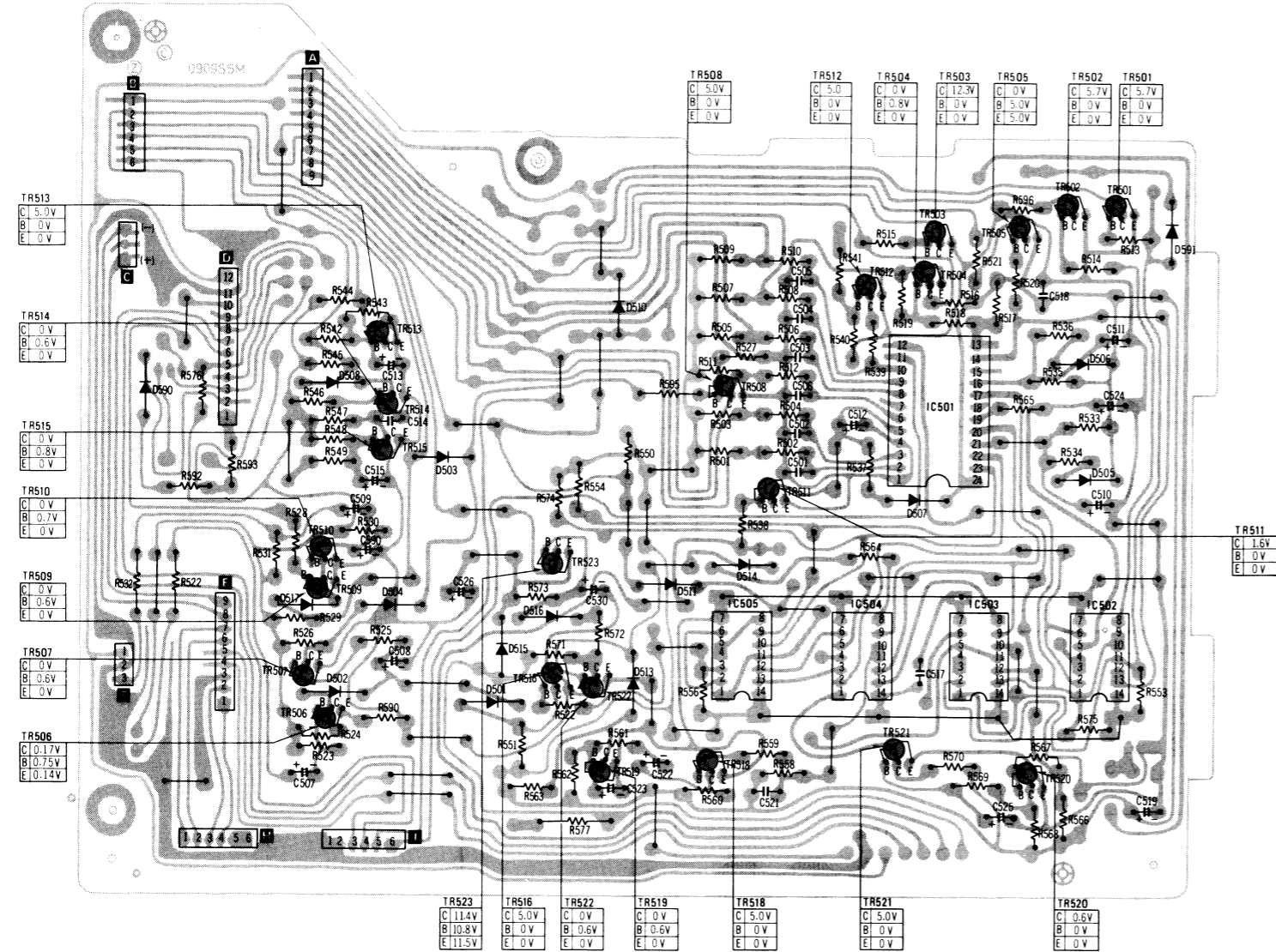

IC (AN6251) equivalent circuitry

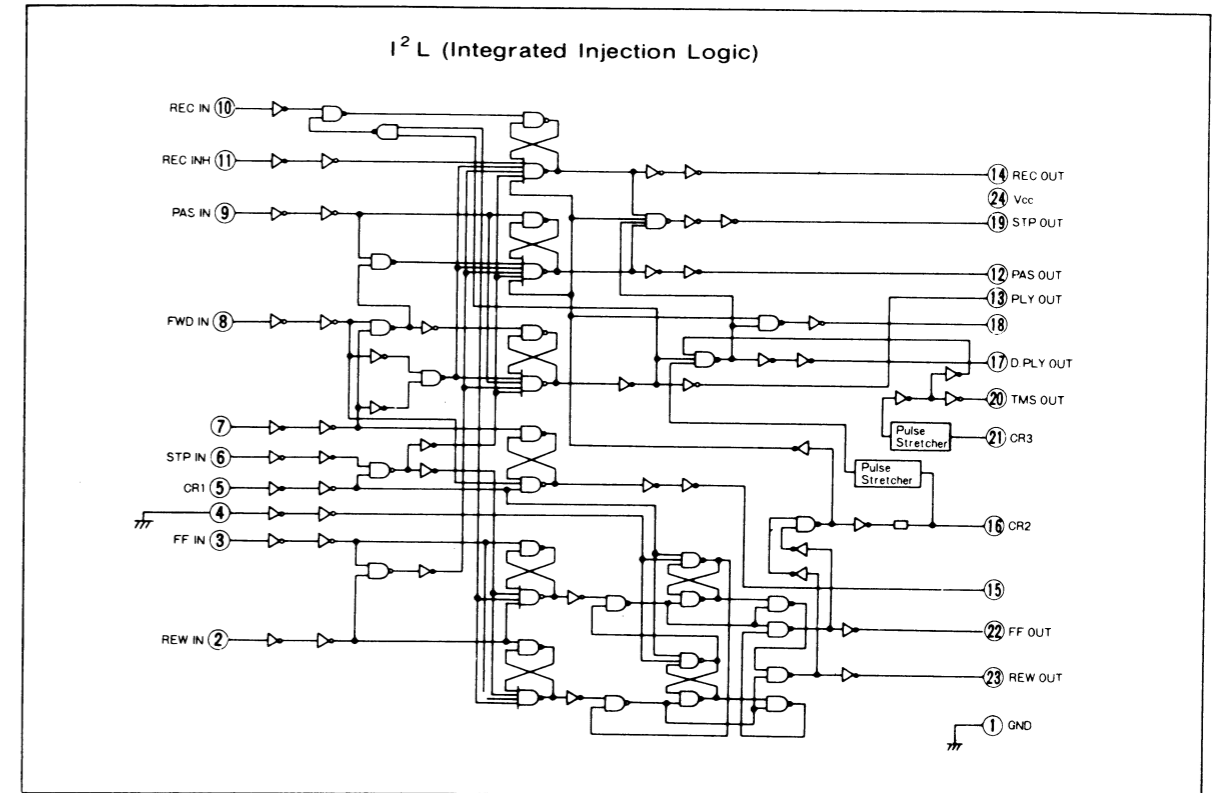

Relationship of each operation mode with input/output

Operation mode	Input terminal	IC (AN6251)							
		Output terminal							
		(12) PAUSE OUT	(13) PLAY OUT	(14) REC OUT	(17) D-PLAY OUT	(19) STOP OUT	(20) TMS OUT	(22) FF OUT	(23) REW OUT
REW	(2) REW IN	H	H	H	H	H	H	H	L
FF	(3) FF IN	H	H	H	H	H	H	L	H
PLAY	(8) FWD IN	H	L	H	*L	H	H	H	H
PAUSE	(9) PAS IN	L	H	H	H	H	H	H	H
REC	(10) REC IN	H	H	L	H	H	H	H	H
STOP	(6) STOP IN	H	H	H	H	L	H	H	H

* Doesn't become "L" immediately even if playback button pushed; becoming "L" after a slight delay.

Plunger Driving

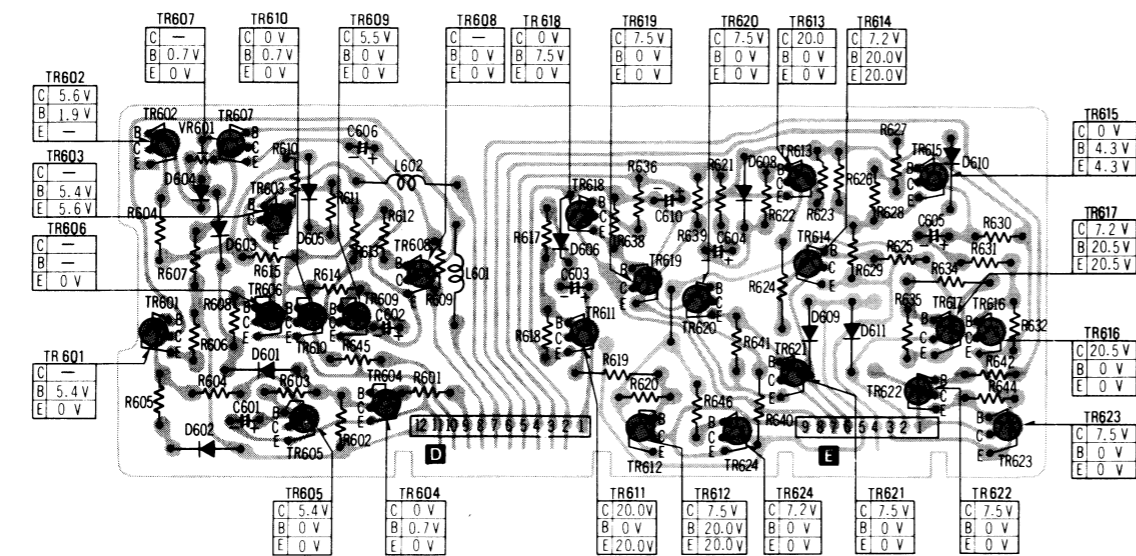

Hall IC

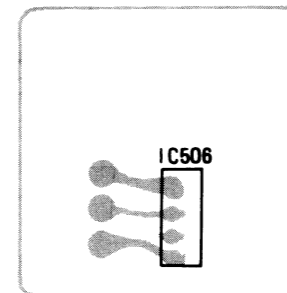

Control Key Switch

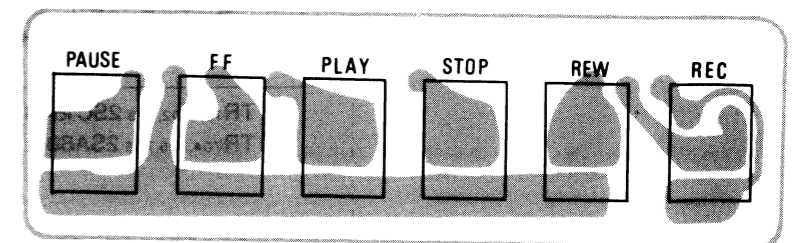

SCHEMATIC DIAGRAM

Capstan Driving Section

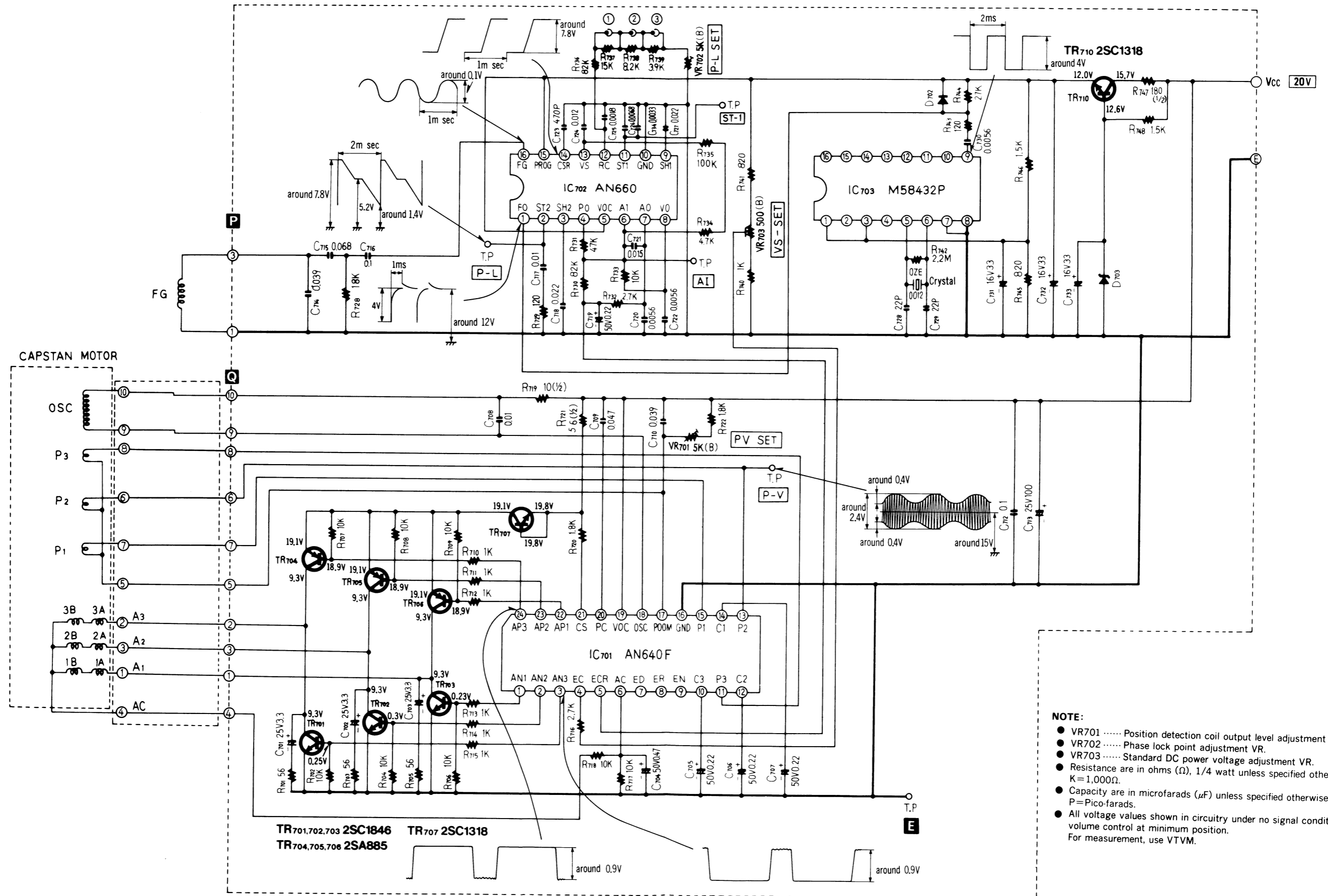

BLOCK DIAGRAM Capstan Motor Section

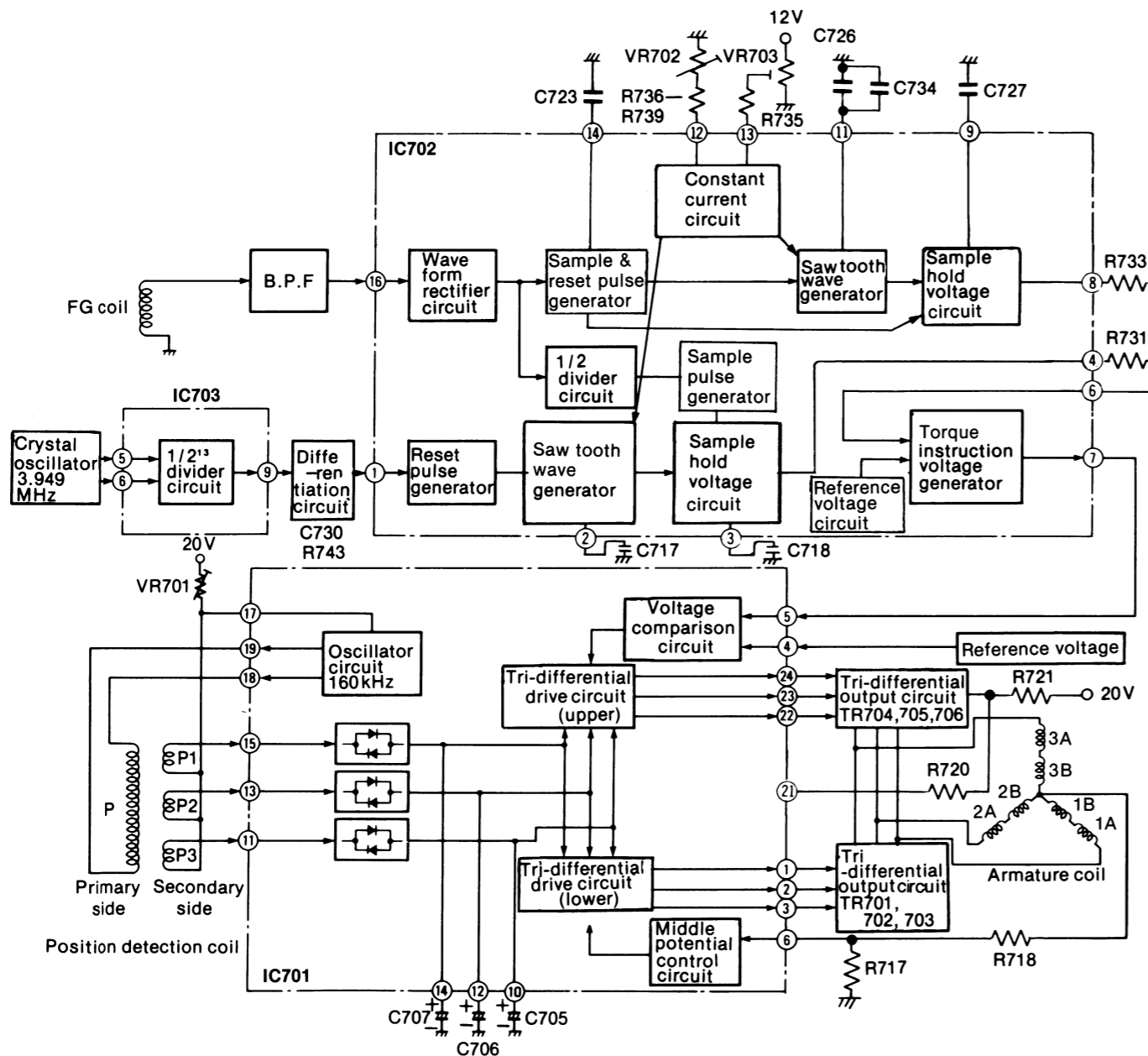

CIRCUIT BOARD Capstan Driving

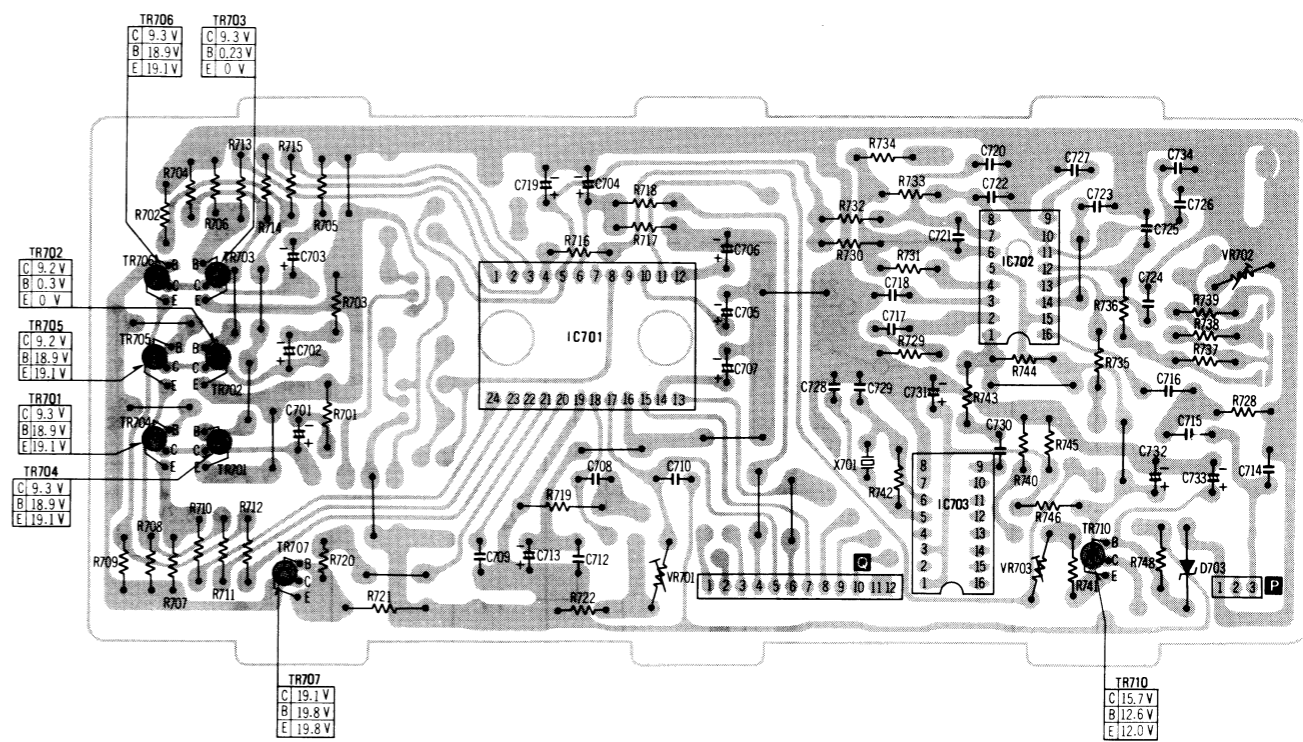

Power Supply

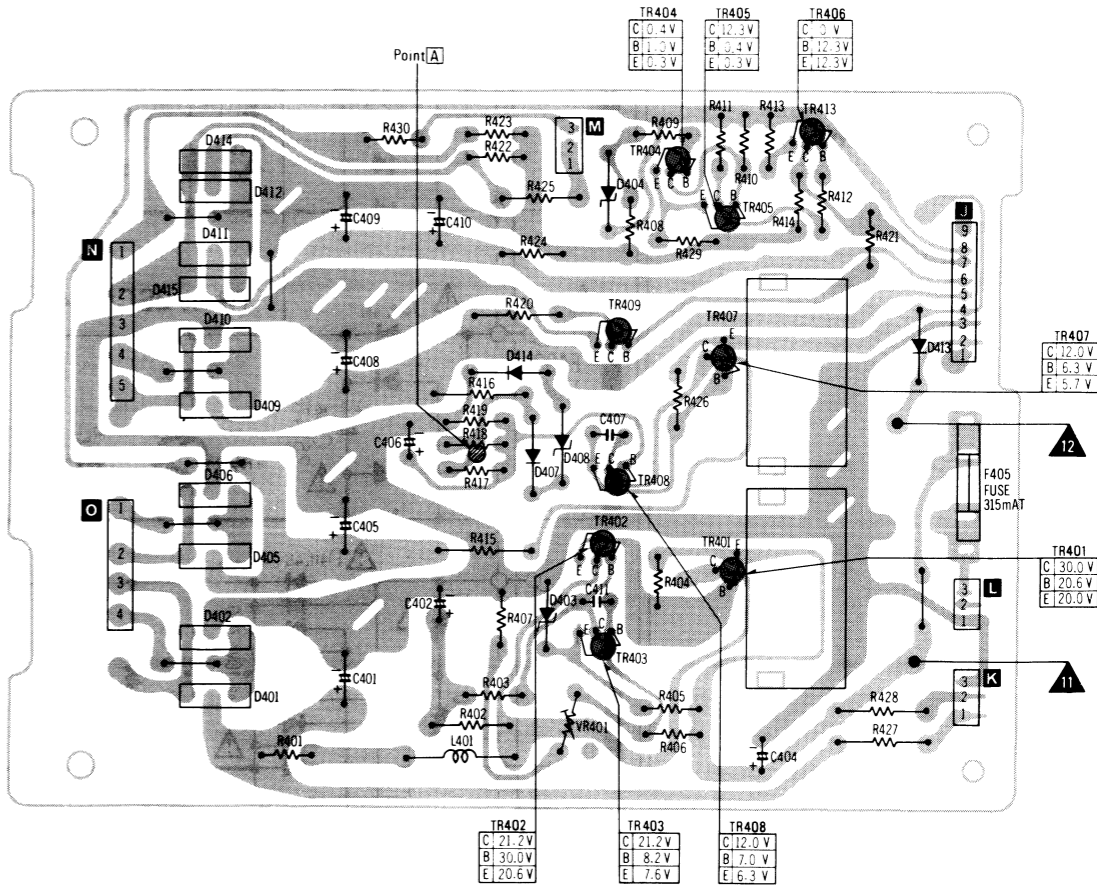

NOTE:
The circuit shown in red on the conductor is B circuit.
Values indicated in are DC voltage between the chassis and electrical parts.

SCHEMATIC DIAGRAM

Power Supply Section

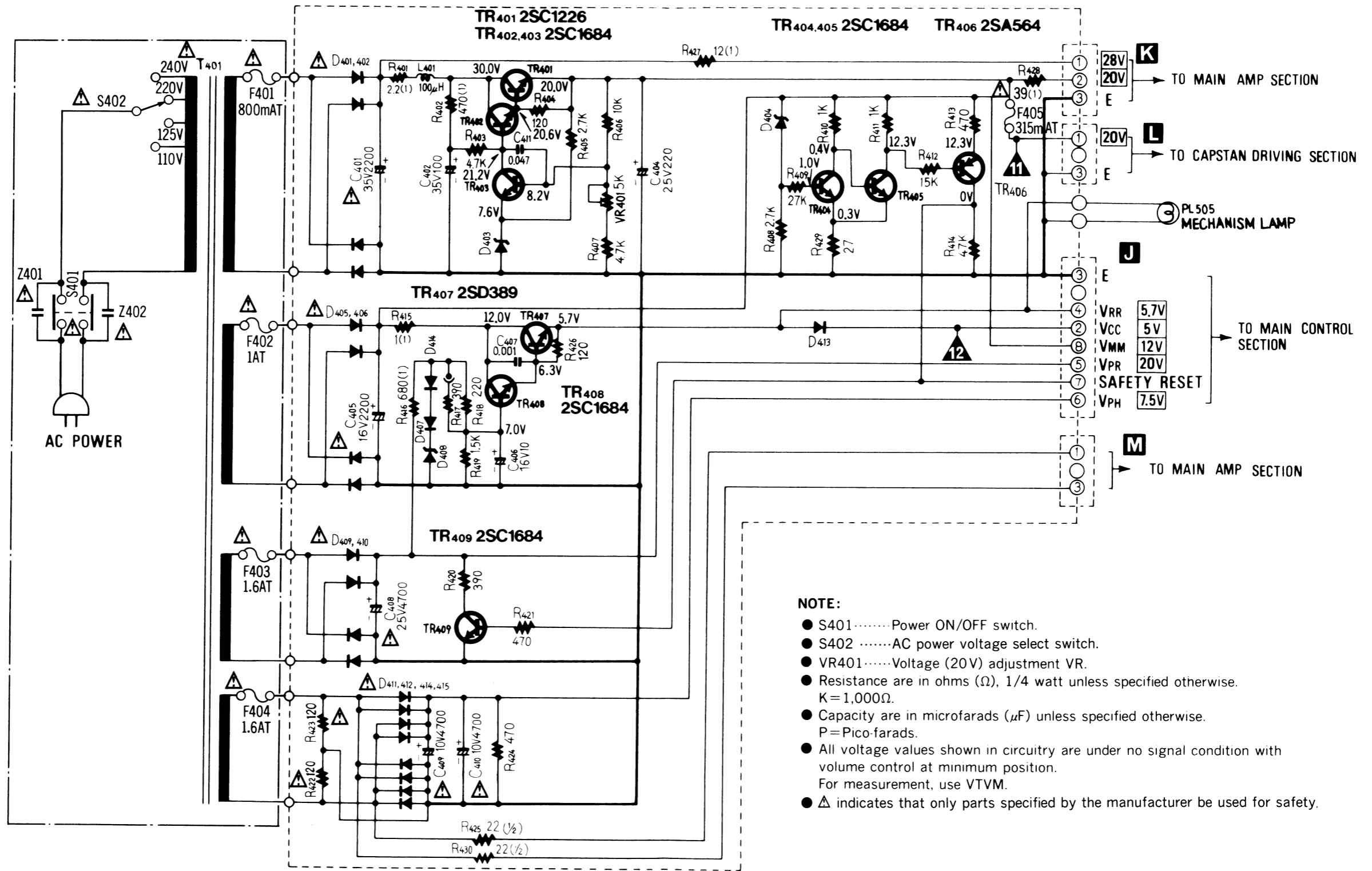

WIRING CONNECTION DIAGRAM

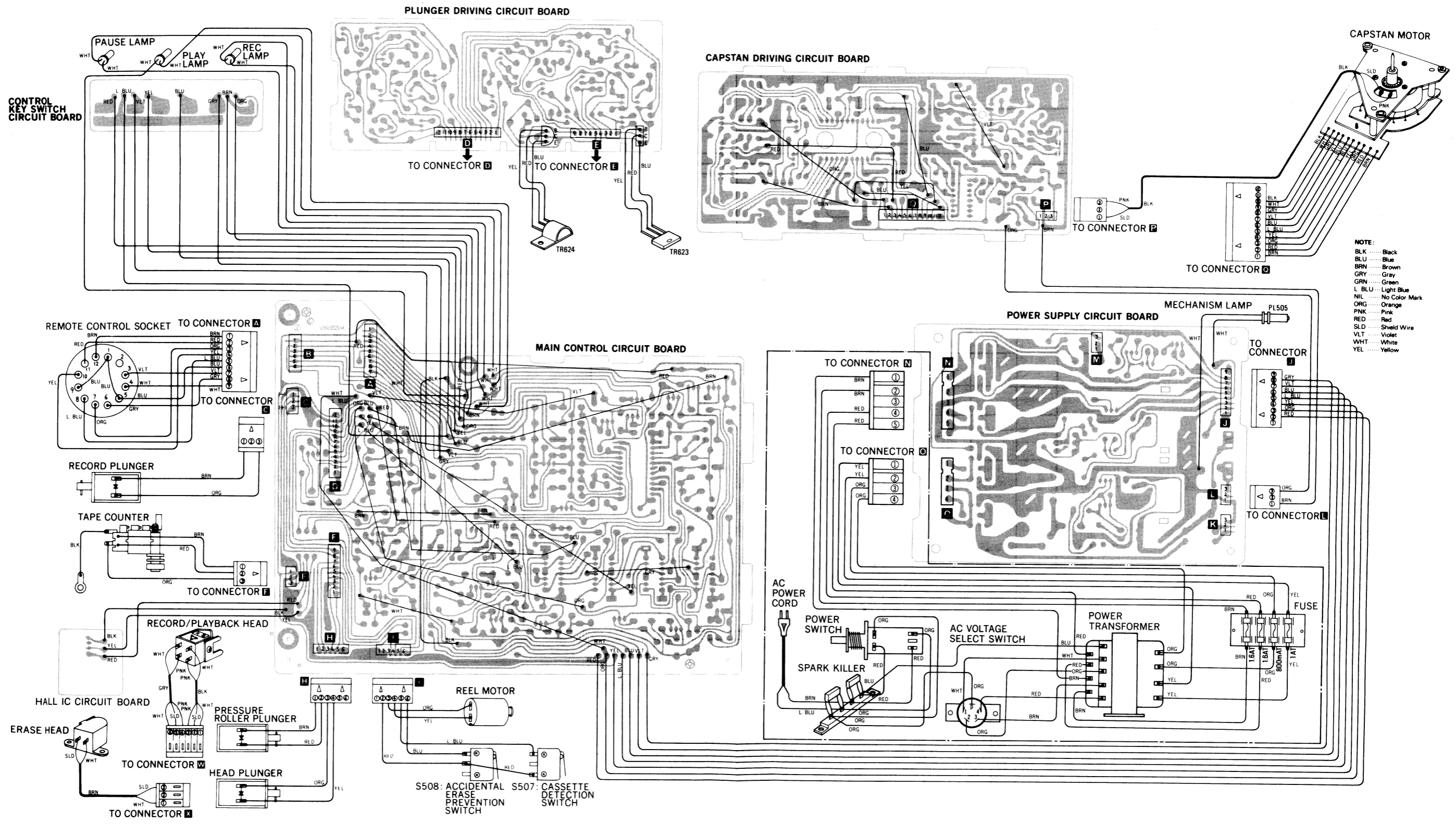

WIRING CONNECTION DIAGRAM

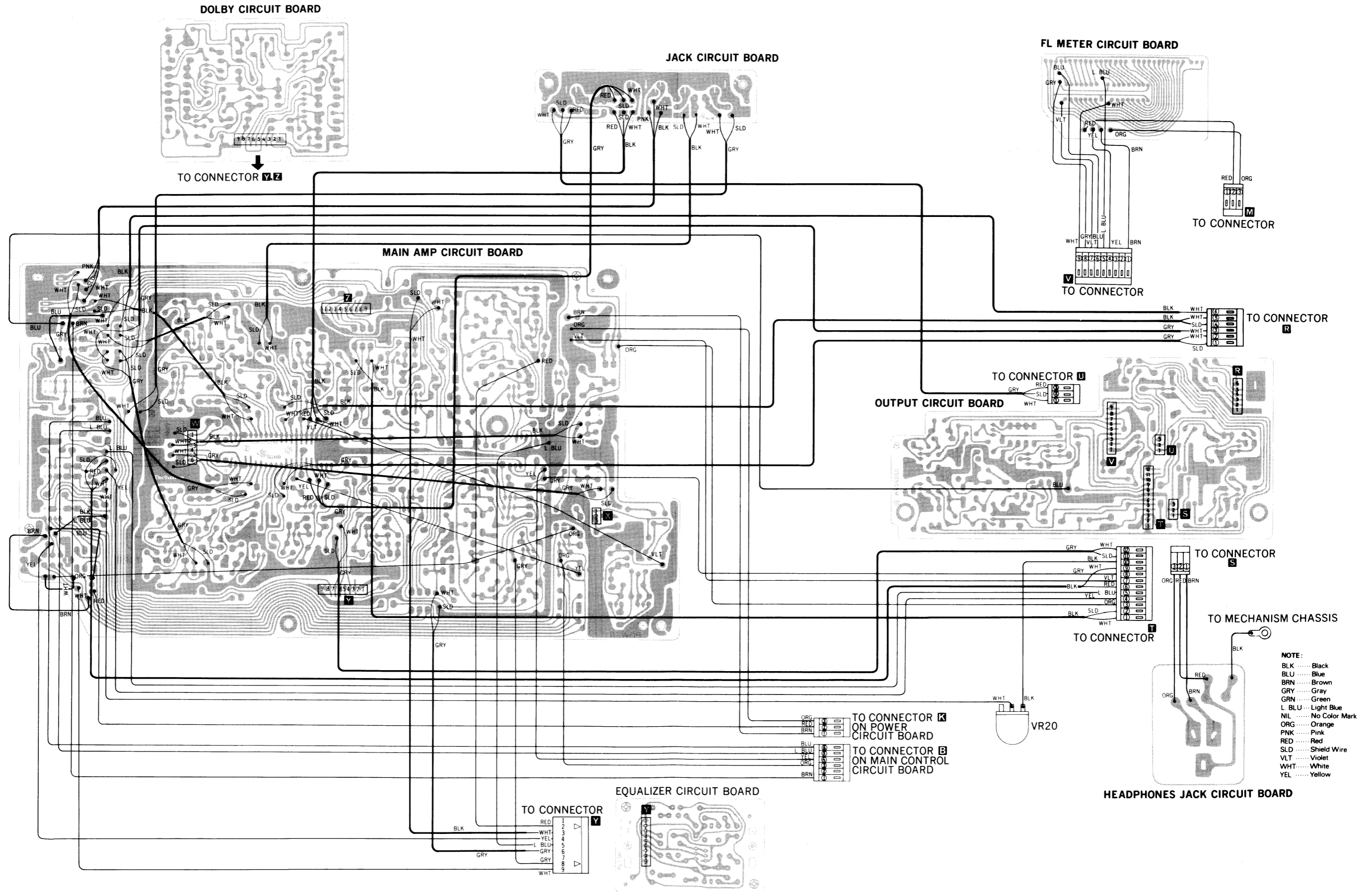

ELECTRICAL PARTS LOCATION

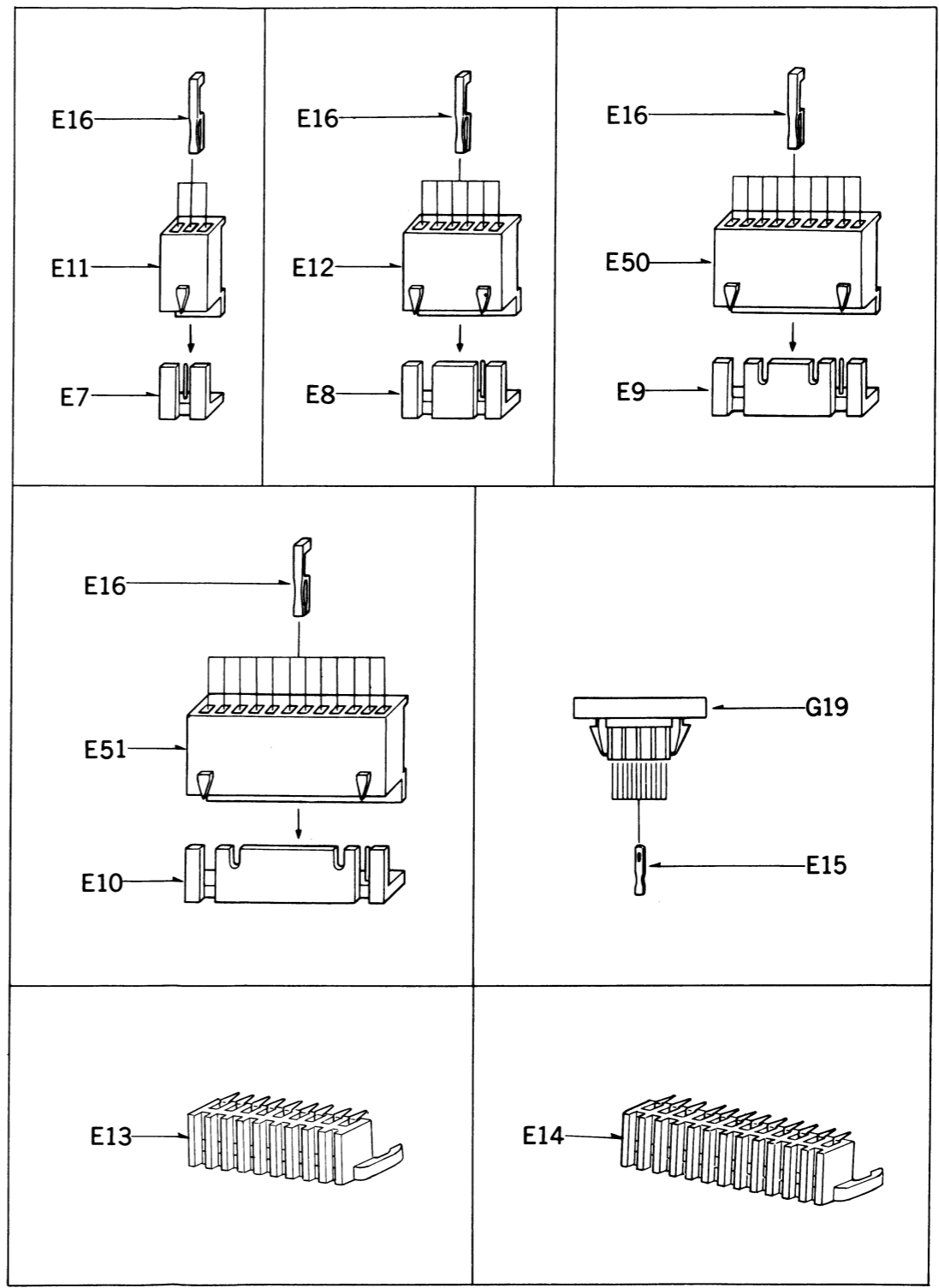
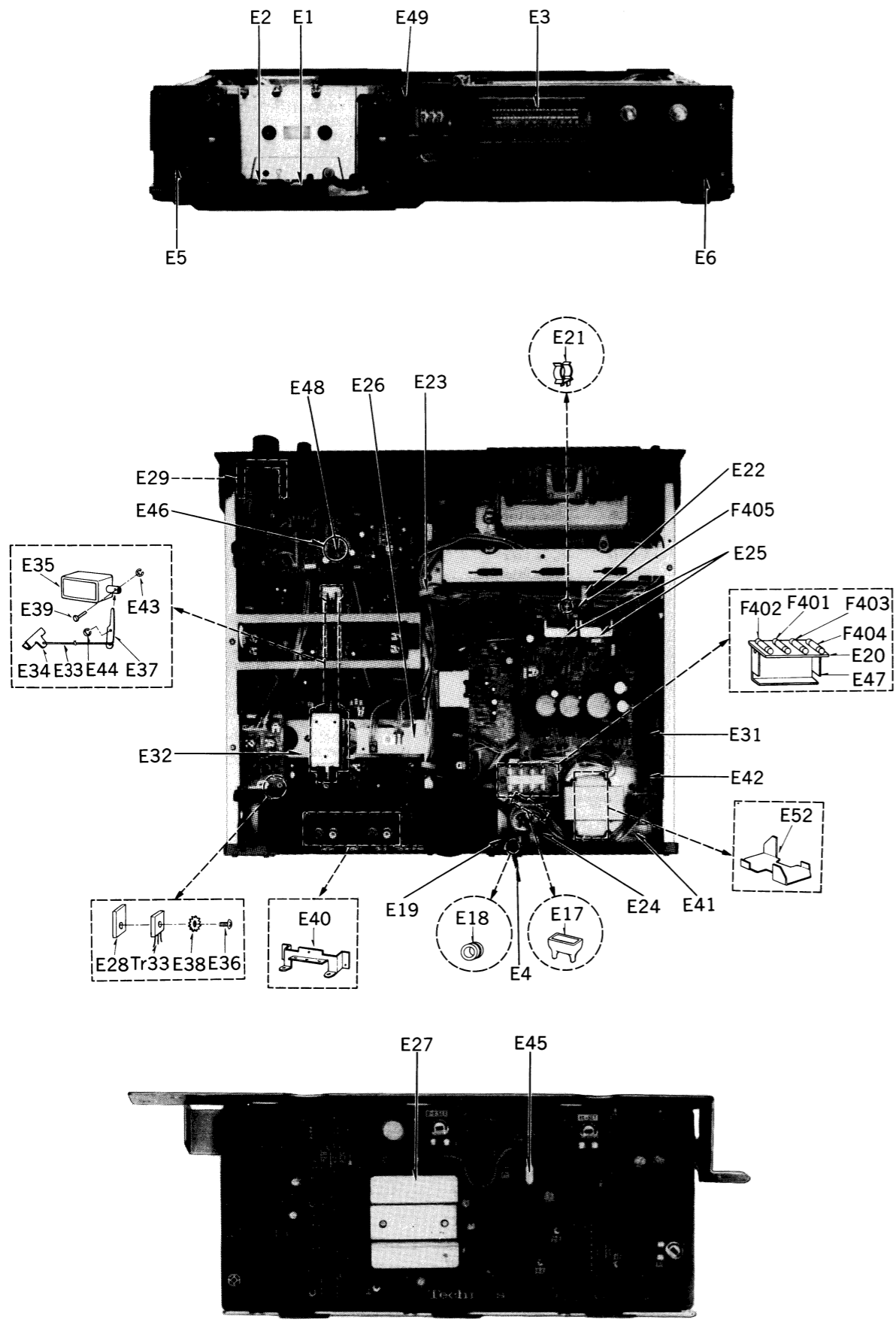

NOTE: Δ indicates that only parts specified by the manufacturer be used for safety.

Ref. No.	Part No.	Part Name & Description
ELECTRICAL PARTS		
E1	WY1402BZ	Record/Playback Head
E2	QWY2133Z	Erase Head
E3	QSL5002RF	Fluorescent Level Meter
E4	QFC1204M	AC Power Cord
*For All European areas except United Kingdom.		
	QFC1205M	"
*For United Kingdom.		
E5	QJA0249H	Headphones Jack
E6	QJA0444H	Microphone Jack
E7	QJP1921TN	3 Pin Post
E8	QJP1922TN	6 Pin Post
E9	QJP1923TN	9 Pin Post
E10	QJP1924TN	12 Pin Post
E11	QJS1921TN	3 Pin Socket
E12	QJS1922TN	6 Pin Socket
E13	QJS1923TNL	9 Pin Socket
E14	QJS1924TNL	12 Pin Socket
E15	QJT1053	Contact-A
E16	QJT1054	Contact-B
E17	QTW1118	Spark Killer Cover
E18	Δ QBJ1425	AC Cord Bushing
E19	QTD1164	AC Cord Clamper
E20	Δ QTF1039	Fuse Holder
E21	QTF1054	Fuse Holding Terminal
E22	QTD1244XN	Wire Clamper-S
E23	QTD1250XN	Wire Clamper-L
E24	QJT4017	4 Pin Terminal
E25	QTH1088	Heat Sink
E26	QMF1980	"
E27	QTH1136	"
E28	QTH1118	"
E29	QTS1423	Shield Plate
E31	QXR0385	Power Switch Rod Assembly
	"Black Type"	"
	QXR0424	"
	"Silver Type"	"
E32	QXA0661	Record/Playback Angle Assembly
E33	QBS1116	Record/Playback Rod
E34	QML3283	Record/Playback Lever
E35	QME0141	Record Plunger
E36	XSN26+8	Screw ϕ 2.6x8
E37	QML3281	Record Lever
E38	XWC26	Lock Washer
E39	QMN2095	Plunger Pin
E40	QMA3300	Jack Angle
E41	QMA3297	Power Switch Angle
E42	QKJ0242	Cap
E43	XUC25FT	Stop Ring 2.5 ϕ
E44	XUC3FT	Stop Ring 3 ϕ
E45	QZE0012	Crystal
E46	QJT1040	Contact
E47	QMA3404	Fuse Angle
E48	QJT1067	Post
E49	QJT0015	Lug Terminal
E50	QJS1923TN	9 Pin Housing
E51	QJS1924TN	12 Pin Housing
E52	QMA3296A	Transformer Angle

EXPLODED VIEWS

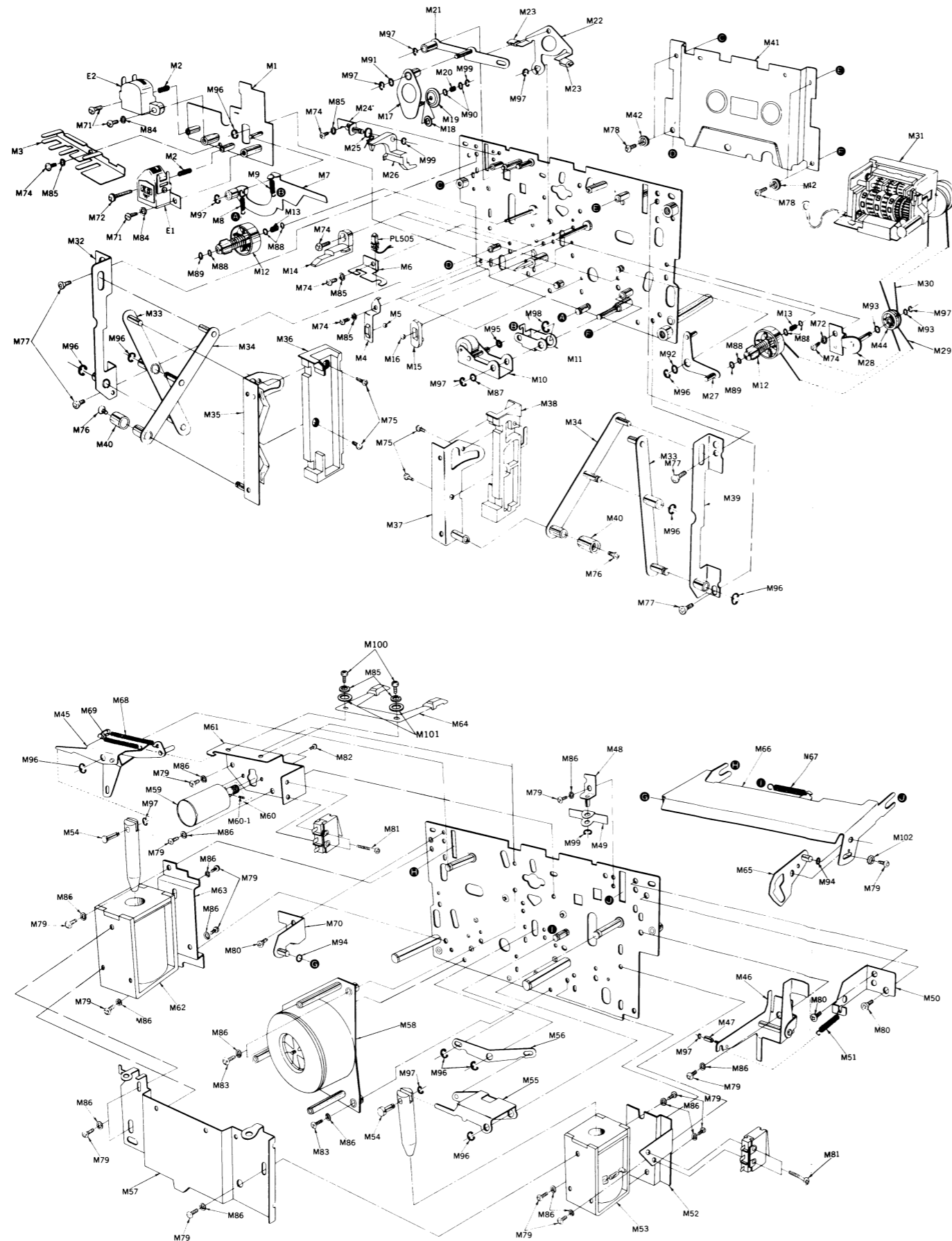

Ref. No.	Part No.	Part Name & Description	Ref. No.	Part No.	Part Name & Description
MECHANICAL PARTS					
M1	QXK2029	Head Base Plate Assembly	M60-1	XXE26D3FZ	Set Screw
M2	QBCA0008	Head Spring	M61	QMA3313	Motor Angle
M3	QTD1261	Head Wires Clamper	M62	QXE0243	Plunger
M4	QBP1733	Steel Ball Holder-A	M63	QMA3312	Plunger Angle-R
M5	QDK1012	Steel Ball 2.5φ	M64	QXH0276	Cassette Holding Cushion
M6	QMA3321	Lamp Angle	M65	QXL1173	Lock Lever Assembly
M7	QXL1168	Pressure Roller Lever Assembly	M66	QML3282	Connector Lever
M8	QBT1490	Eject Lever Spring	M67	QBT1553	Holder Spring-R
M9	QBT1441	Pressure Roller Spring	M68	QBT1405	Lever Spring
M10	QXL1166	Pressure Roller Assembly	M69	QBT1713	Record Spring
M11	QML3267	Pressure Roller Lever-1	M70	QXA0702	Connector Angle-R Assembly
M12	QXD0087	Reel Table	M71	XSN2+6	Screw ⊕2×6
M13	QBC1272	Back Tension Spring	M72	QH01211	Head Adjustment Screw
M14	QMG0054	Cassette Guide	M74	XSN26+4	Screw ⊕2.6×4
M15	QMH2009	Steel Ball Holder-B	M75	XSN26+4BV	Screw ⊕2.6×4
M16	QDK1006	Steel Ball 3φ	M76	XSS2+4	Screw ⊕2×4
M17	QXL1189	Idler Lever Assembly	M77	XSS3+4S	Screw ⊕3×4
M18	QBF1260	Idler Felt	M78	QH01185	Step Screw
M19	QX10101	Idler Assembly	M79	XSN3+5S	Screw ⊕3×5
M20	QBC1308	Idler Spring	M80	XSS3+6S	Screw ⊕3×6
M21	QXL1164	Brake Lever Assembly	M81	QH01182	Step Screw
M22	QML3273	Brake	M82	XSN2+3	Screw ⊕2×3
M23	QBG1132	Stopper Rubber	M83	XSN3+8S	Screw ⊕3×8
M24	QXA0714	Detection Angle Assembly	M84	XWA2B	Spring Washer 2φ
M25	QBN1573	Detection Lever Spring	M85	XWA26B	Spring Washer 2.6φ
M26	QML3285	Detection Lever	M86	XWA3B	Spring Washer 3φ
M27	QXL1172	Lever-A Assembly	M87	QBW2016	Poly Washer
M28	QXA0712	Pulley Angle Assembly	M88	QBW2012	"
M29	QDB0218	Counter Belt-A	M89	QBW2008	"
M30	QDB0234	Counter Belt-B	M90	QBW2015	"
M31	QXC0021	Tape Counter Assembly	M91	QBW2017	"
	QXC0029	"Black Type"	M92	QBW2018	"
	QXC0029	"Silver Type"	M93	QBW2016	"
M32	QXA0703	Angle-L Assembly	M94	QBW2019	"
M33	QXL1191	Link Lever-A Assembly	M95	QBK7123	Fiber Washer
M34	QXL1190	Link Lever-B Assembly	M96	XUC3FT	Stop Ring 3φ
M35	QXA0706	Holder Angle-L Assembly	M97	XUC25FT	Stop Ring 2.5φ
M36	QMH2027	Cassette Holder-L	M98	XUC5FT	Stop Ring 5φ
M37	QXA0705	Holder Angle-R Assembly	M99	XUC2FT	Stop Ring 2φ
M38	QMH2028	Cassette Holder-R	M100	XSN26+6	Screw ⊕2.6×6
M39	QXA0704	Angle-R Assembly	M101	XWG26	Flat Washer
M40	QKJ0245	Spacer-A	M102	XWC3B	Lock Washer
M41	QXH0286	Mechanism Cover			
M42	QMZ1213	Spacer-B			
M43	QBP1135	Spring Washer			
M44	QDP1753	Connection Pulley			
M45	QXL1165	Lever-B Assembly			
M46	QXL1188	Eject Lever Assembly			
M47	QDP1758	Roller			
M48	QXA0713	Angle Assembly			
M49	QML3284	Release Lever			
M50	QMA3314	Connector Angle			
M51	QBT1753	Playback Lever Spring			
M52	QMA3311	Plunger Angle-L			
M53	QME0141	Plunger			
M54	QMN2095	Plunger Pin			
M55	QXL1171	Plunger Lever-L Assembly			
M56	QML3276	Plunger Lever			
M57	QMA3322	Reinforcement Angle			
M58	QXK2010	Capstan Motor Assembly			
M59	MKCN22AE5	Reel Motor			
M60	QXP0574	Motor Pulley Assembly			

SPECIFICATIONS

Pressure of pressure roller	400 ± 30 gr
Wow and flutter: JIS (Test tape..... QZZCWAT)	Less than 0.04% (WRMS)